

# KERTAS SOALAN PEPERIKSAAN SEBENAR SPM 2021 FORMAT TERKINI

**+3 SET**  
KERTAS MODEL  
FORMAT INSTRUMEN  
SPM TERKINI

## MATEMATIK

### SIJIL PELAJARAN MALAYSIA 2021

#### KERTAS 1

1 **D**

**A:** 1 050 kilometer/kilometre =  $1.05 \times 10^3$  kilometer/kilometre → Salah/Incorrect

**B:** 0.75 teraliter/teralitre =  $7.5 \times 10^{-1}$  teraliter/teralitre → Salah/Incorrect

**C:** 0.089 fentometer/fentometre =  $8.9 \times 10^{-2}$  fentometer/fentometre → Salah/Incorrect

**D:** 2 160 gigabait/gigabyte =  $2.16 \times 10^3$  gigabait/gigabyte → Betul/Correct

2 **C**

**A, B dan D** menerangkan kelebihan kad kredit.

**A, B and D** explains the advantages of credit card.

3 **D**

$$P = \text{RM3 000}$$

$$R = 5\% \text{ atau } 0.05 \text{ setahun}$$

5% or 0.05 per year

$$n = 2$$

$$t = 5$$

$$\begin{aligned} MV &= P \left( 1 + \frac{r}{n} \right)^{nt} \\ &= 3000 \left( 1 + \frac{0.05}{2} \right)^{2(5)} \\ &= \text{RM3 840.25} \end{aligned}$$

4 **D**

Aset → Menjana pendapatan

Asset → Generate income

Liabiliti → Tidak menjana pendapatan

Liability → Does not generate income



5 D

**A:** Cukai jalan → Dikenakan cukai kepada pengguna jalan raya yang memiliki kenderaan termasuk motosikal dan kereta.

*Road tax → Taxed to road users who own vehicles including motorcycles and cars.*

**B:** Cukai pintu → Dikenakan cukai kepada semua pegangan atau harta tanah.

*Property assessment tax → Taxed to all holdings or real estate.*

**C:** Cukai pendapatan → Dikenakan cukai atas pendapatan.

*Income tax → Taxed on income.*

**D:** Cukai jualan dan perkhidmatan → Dikenakan cukai terhadap pengguna yang menggunakan perkhidmatan bercukai tertentu seperti perkhidmatan hotel, insurans dan takaful, penyedia makanan dan minuman, telekomunikasi, kad kredit dan sebagainya.

*Sale and service tax → Taxed on consumers who use certain taxable services such as hotel services, insurance and takaful, food and beverage providers, telecommunications, credit cards and etc.*

6 B

**A:** Graf berakhir bukan pada jarak 0 km seperti yang ditunjukkan dalam Jadual 1.

*The graph ends not at a distance of 0 km as shown in Table 1.*

**B:** Menepati data yang ditunjukkan dalam Jadual 1.

*Adhere to the data shown in Table 1.*

**C:** Jarak semakin jauh (meningkat), yang mana tidak sama dengan data dalam Jadual 1 yang menunjukkan jarak semakin dekat (menurun).

*The distance is getting further (increasing), which is not the same as the data in Table 1 that shows the distance is getting closer (decreasing).*

**D:** Graf bermula pada jarak 0 km, yang mana tidak sama dengan data dalam Jadual 1 yang bermula pada jarak 3.2 km.

*The graph starts at a distance of 0 km, which is not the same as the data in Table 1 that starts at a distance of 3.2 km.*

7 C

Graf laju-masa/Speed-time graph:

Jarak = Luas bawah graf

*Distance = Area under the graph*

$$(8 - 2) \times u + \frac{1}{2} \times (10 + u) \times 2 = 220$$

$$6u + 10 + u = 220$$

$$7u = 220 - 10$$

$$u = 30$$

8 B

$R(R, 0)$

$S(S, 0)$

$$f(x) = x^2 - 7x - 8$$

$$0 = x^2 - 7x - 8$$

$$0 = (x + 1)(x - 8)$$

$$x + 1 = 0$$

$$x = -1$$

$$x - 8 = 0$$

$$x = 8$$

Titik R berada pada bahagian negatif pada paksi-x, maka:

*Point R is on the negative side of the x-axis, then:*

$R(-1, 0)$

Titik S berada pada bahagian positif pada paksi-x, maka:

*Point S is on the positive side of the x-axis, then:*

$S(8, 0)$

9 B

$$p \propto \frac{1}{\sqrt{q}}$$

$$p = \frac{k}{\sqrt{q}}$$

$$4 = \frac{k}{\sqrt{25}}$$

$$k = 4 \times 5$$
$$= 20$$

$$p = \frac{20}{\sqrt{q}}$$

10 B

$$m = \frac{y_2 - y_1}{x_2 - x_1}$$

$$m = \frac{3 - 0}{0 - (-6)}$$

$$= \frac{3}{6}$$

$$= \frac{1}{2}$$

11 D

Faktor skala/Scale factor

$$= \frac{\text{Imej/Image}}{\text{Objek/Object}}$$

$$= \frac{3}{1}$$

$$= 3$$

12 C

Graf/Graph  $\sin 2x$ :

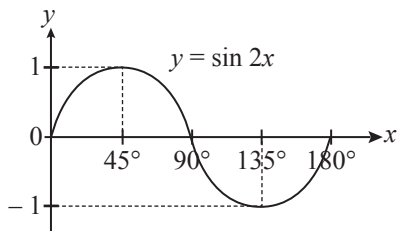

Maka, graf  $y = \sin 2x$  bagi  $90^\circ \leq x \leq 270^\circ$  adalah

Hence, the graph represents  $y = \sin 2x$  for  $90^\circ \leq x \leq 270^\circ$  is

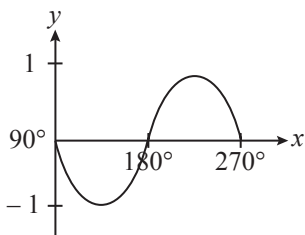

13 B

Lokus  $x$  bergerak 6 cm dari titik  $R =$  titik **A** dan **B**

*Locus  $x$  moves 6 cm from point  $R =$  point **A** and **B***

Lokus  $y$  bergerak jarak sama dari garis  $PQ$  dan  $SR =$  titik **B** dan **D**

*Locus  $y$  moves such that it is equidistance from line  $PQ$  and  $SR =$  point **B** and **D***

Titik yang memenuhi kedua-dua syarat ialah titik **B**.

*The point that meets both conditions is point **B**.*

14 C

$$VPQ = VQR = VUR = 18$$

$$US = \frac{1}{2}UR$$

$$\therefore k = \frac{1}{2}$$

$$k^2 = \frac{\text{luas imej/area of image}}{\text{luas objek/area of object}}$$

$$\left(\frac{1}{2}\right)^2 = \frac{UST}{18}$$

$$UST = 4.5$$

$$\begin{aligned} \text{Jumlah luas/Total area} &= 3(18) + 4.5 \\ &= 58.5 \text{ cm}^2 \end{aligned}$$

15 B

$$\begin{aligned} PS + RQ &= 100 + 150 \\ &= 250 \end{aligned}$$

16 B

$$\xi = \{10, 11, 12, 13, 14, 15, 16, 17, 18, 19, 20\}$$

$$P \cup Q = \{12, 14, 15, 16, 17, 18\}$$

$$(P \cup Q)' = \{10, 11, 13, 19, 20\}$$

17 B

Hujah deduktif:

*Deductive argument:*

Premis 1: Jika  $P$ , maka  $Q$ .

*Premise 1: If  $P$ , then  $Q$ .*

Premis 2: Bukan  $Q$  adalah benar.

*Premise 2: Not  $Q$  is true.*

Kesimpulan: Bukan  $P$  adalah benar.

*Conclusion: Not  $P$  is true.*

Premis 1: Jika  $m \div 8 = -2$ , maka  $m = -6$ .

*Premise 1: If  $m \div 8 = -2$ , then  $m = -6$ .*

Premis 2 :  $m = 16$

*Premise 2*

Kesimpulan:  $m \div 8 \neq -2$

*Conclusion:  $m \div 8 \neq -2$*

18 C

A: Julat/Range 23 hingga/to 27 = 5 kali/times

B: Julat/Range 38 hingga/to 38 = 6 kali/times

C: Julat/Range 41 hingga/to 49 = 8 kali/times

D: Julat/Range 50 hingga/to 55 = 5 kali/times

19 B

$$\begin{aligned}\text{Min/Mean} &= \frac{\sum fx}{\sum f} \\ &= \frac{(10.5 \times 2) + (30.5 \times 7) + (50.5 \times 5) + (70.5 \times 11) + (90.5 \times 5)}{2 + 7 + 5 + 11 + 5} \\ &= 57.17\end{aligned}$$

20 B

Kimia/Chemistry:

Lulus/Pass = 0.4

Gagal/Fail = 0.6

Matematik/Mathematics:

Lulus/Pass = 0.7

Gagal/Fail = 0.3

$$0.7 \times 0.4 = 0.28$$

21 A

$$\begin{aligned}\frac{\sqrt{p^4 \times q^4}}{p \times p \times q \times q} &= \frac{(p^4 \times q^4)^{\frac{1}{2}}}{p^2 \times q^2} \\ &= \frac{p^2 \times q^2}{p^2 \times q^2} \\ &= p^{2-2} q^{2-2} \\ &= p^0 q^0 \\ &= p^0\end{aligned}$$

22 A

$$\sqrt{(3.36 \times 10^3)^2 - (3.24 \times 10^3)^2} = 889.9 \text{ cm}$$

$$\begin{aligned}\text{Luas/Area} &= \frac{1}{2} \times (3.24 \times 10^3) \text{ cm} \times 889.9 \text{ cm} \\ &= 1.44 \times 10^6 \text{ cm}^2\end{aligned}$$

23 D

$$m = \frac{\text{mencancang/vertical}}{\text{mengufuk/horizontal}}$$

$$\frac{4}{3} = \frac{2.1}{x}$$

$$x = 1.6$$

$$\begin{aligned}\text{Jarak PR/Distance of PR} &= 4.8 - 1.6 \\ &= 3.2 \text{ cm}\end{aligned}$$

24 C

$$x^2 - 4x = \frac{4}{3} \left( 2 - \frac{x}{2} \right)$$

$$3x^2 - 12x = 8 - 2x$$

$$3x^2 - 12x + 2x - 8 = 0$$

$$3x^2 - 10x - 8 = 0$$

$$(3x + 2)(x - 4) = 0$$

$$x = -\frac{2}{3}x \quad , \quad x = 4$$

25 B

Graf menunjukkan hubungan  $\geq$ . Maka, **B** dan **D** diambil kira.

*The graph shows the relationship of  $\geq$ . Then, **B** and **D** are taken into account.*

$$P(-3, -1)$$

$$Q(3, 8)$$

$$\mathbf{B}: 2y \geq 3x + 7$$

Gantikan koordinat titik *P*/Substitute the coordinates of *P*:

$$2(-1) \geq 3(-3) + 7$$

$$-2 \geq -2(\text{Benar/True})$$

Gantikan koordinat titik *Q*/Substitute the coordinates of *Q*:

$$2(8) \geq 3(3) + 7$$

$$16 \geq 16(\text{Benar/True})$$

26 C

$$pq + 1 = q^2 + p$$

$$pq - p = q^2 - 1$$

$$p(q - 1) = q^2 - 1$$

$$p = \frac{q^2 - 1}{q - 1}$$

$$p = \frac{(q - 1)(q + 1)}{q - 1}$$

$$= q + 1$$

27 B

$$h \propto \frac{1}{t}$$

$$t = 40$$

$$h = 1\,250$$

$$h = \frac{k}{t}$$

$$1\,250 = \frac{k}{40}$$

$$k = 50\,000$$

$$h = \frac{50\,000}{t}$$

$$h = \frac{50\,000}{100}$$

$$= 500 \text{ cm}$$

28 D

$$\begin{pmatrix} 3 & 2 \\ -5 & 4 \end{pmatrix} \begin{pmatrix} 1 \\ -x \end{pmatrix} = \begin{pmatrix} -x \\ -17 \end{pmatrix}$$

$$\begin{aligned} (3)(1) + 2(-x) &= -x \\ 3 - 2x + x &= 0 \\ -x &= -3 \\ x &= 3 \end{aligned}$$

$$\begin{aligned} (-5)(1) + (4)(-x) &= -17 \\ -5 - 4x &= -17 \\ x &= \frac{-17 + 5}{-4} \\ x &= 3 \end{aligned}$$

29 D

$$\begin{aligned} x &= \frac{180^\circ - 70^\circ}{2} \\ &= 55^\circ \\ y &= 180^\circ - 65^\circ - 55^\circ \\ &= 60^\circ \end{aligned}$$

30 C

$$\begin{aligned} 1 : m \\ P &= 1\ 386 \\ Q &= 154 \end{aligned}$$

$$\begin{aligned} P: \frac{22}{7} \times r^2 &= 1\ 386 \\ r &= 21 \end{aligned}$$

$$\begin{aligned} Q: \frac{22}{7} \times r^2 &= 154 \\ r &= 7 \end{aligned}$$

$$\begin{aligned} \text{Imej/Image : Objek/Object} \\ &= 7 : 21 \\ &= \frac{7}{7} : \frac{21}{7} \\ &= 1 : 3 \end{aligned}$$

$$\therefore m = 3$$

31 D

A:

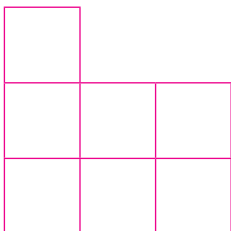

**B:**

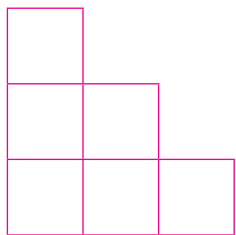

**C:**

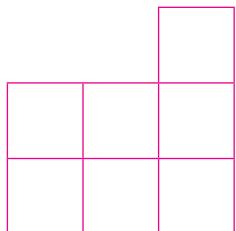

**D:**

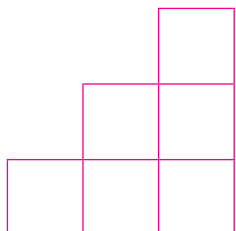

**32 D**

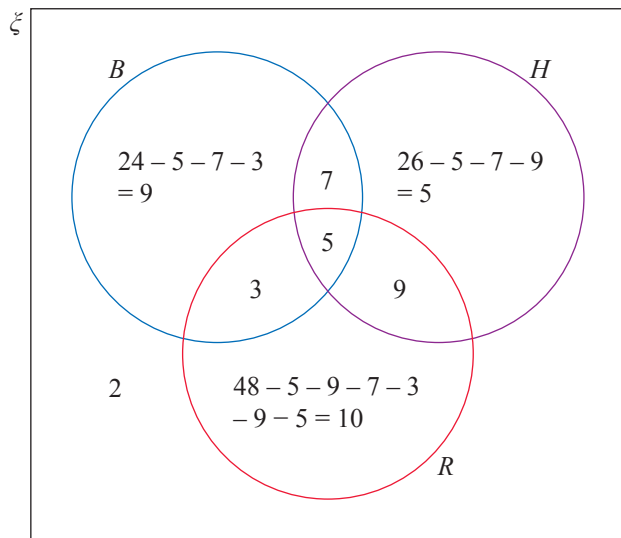

33 A

$$MM : MT = 2 : 1$$

$$60 - 8 - 11 - 10 - 10 = 21$$

$$3 \text{ bahagian/parts} = 21$$

$$1 \text{ bahagian/part} = \frac{21}{3}$$
$$= 7$$

$$MM = 2 \times 7 = 14 \text{ orang murid/students}$$

$$MT = 1 \times 7 = 7 \text{ orang murid/students}$$

Jumlah kutipan yuran/*Total fee collection*

$$= (8 \times 3) + (11 \times 5) + (10 \times 5) + (10 \times 5) + (14 \times 4) + (7 \times 6)$$
$$= 277$$

34 C

{GE, GT, EG, ET, TE, TG}

35 A

Harga jualan/*Selling price* = RM550 000

$$t = 5$$

$$\text{Wang pendahuluan/Deposit} = \frac{10}{100} \times 550\,000$$
$$= 55\,000$$

Jumlah pendapatan/*Total income* = RM7 200

Perbelanjaan/*Expenses* = RM4 000

$$7\,200 - 4\,000 - \frac{55\,000}{5 \times 12} = \text{RM}2\,283.33$$

36 (Tidak ada dalam pilihan jawapan/*None in the answer choices*)

$$(17 \times 100) \times (4 \times 100) = 680\,000$$

$$680\,000 - 2(200 \times 200) - (100 \times 300) = 570\,000$$

$$\frac{570\,000}{28\,000} = 20.36$$

$$= 21 \text{ tin cat/can of paint}$$

37 B

$$\begin{pmatrix} 5 & -2 \\ -7 & 3 \end{pmatrix} \begin{pmatrix} 2 \\ 3 \end{pmatrix} = \frac{1}{2x} \begin{pmatrix} 16 \\ -20 \end{pmatrix}$$

$$5(2) + (-2)(3) = \frac{16}{2x}$$

$$10 - 6 = \frac{16}{2x}$$

$$2x = 4$$

$$x = 2$$

38 C

$$\frac{25}{100} \times x = 15$$

$$x = 60$$

$$\frac{1}{2} \times 60 = 30$$

Kekerapan longgokan

*Cumulative frequency*

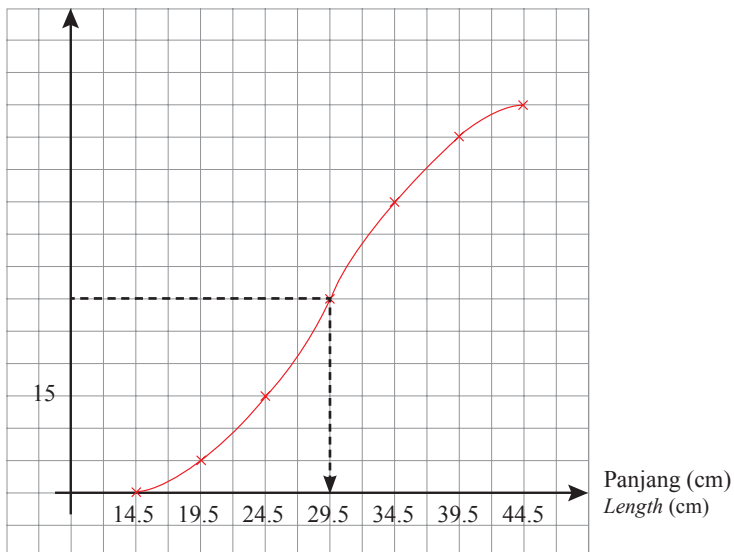

Median panjang/*Median of length* = 29.5

39 D

$$\begin{aligned} \text{Isnin/Monday} &: 100110_2 \\ &= (1 \times 2^5) + (1 \times 2^2) + (1 \times 2) \\ &= 38 \text{ pengunjung/visitors} \end{aligned}$$

Selasa/Tuesday: 55 pengunjung/visitors

$$\begin{aligned} \text{Rabu/Wednesday} &: 2201_3 \\ &= (2 \times 3^3) + (2 \times 3^2) + (1 \times 3^0) \\ &= 73 \text{ pengunjung/visitors} \end{aligned}$$

$$\begin{aligned} \text{Khamis/Thursday} &: 124_8 \\ &= (1 \times 8^2) + (2 \times 8^1) + (4 \times 8^0) \\ &= 84 \text{ pengunjung/visitors} \end{aligned}$$

$$\begin{aligned} \text{Purata/Mean} &= \frac{38 + 55 + 73 + 84}{4} \\ &= 62.5 \text{ pengunjung/visitors} \end{aligned}$$

40 B

- I: Kelebihan menggunakan kad kredit  
*The advantages of using credit card*
- II: Kelemahan menggunakan kad kredit  
*The disadvantages of using credit card*
- III: Kelemahan menggunakan kad kredit  
*The disadvantages of using credit card*
- IV: Kelebihan menggunakan kad kredit  
*The advantages of using credit card*

∴ I dan/and IV

**KERTAS 2**

No.	Skema Pemarkahan Marking Scheme	Markah Marks	Markah Total Total Marks
1	$4 \text{ sisi/sides} = 4x + 4$ $1 \text{ sisi/side} = \frac{4x + 4}{4} = x + 1$ Luas/Area = $(x + 1)(x + 1)$	1 1	2
2	(a) Beza di antara jujukan/Difference between a sequence $= \left( \frac{5}{3} - \frac{1}{3} \right) \div 2$ $= \frac{2}{3}$ $J = \frac{1}{3} + \frac{2}{3}$ $= \frac{3}{3}$ $= 1$ $K = \frac{5}{3} + \frac{2}{3}$ $= \frac{7}{3}$	1	3
	(b) Tambah $\frac{2}{3}$ kepada nombor yang sebelumnya. Add $\frac{2}{3}$ to the previous number.	1	
3	$m = 0.25$ (a) Kecerunan/Gradient = $\frac{\text{Mengufuk/Horizontal}}{\text{Mencancang/Vertical}}$ $0.25 = \frac{1.25}{x}$ $x = 6$ $\tan \theta = \frac{1.5}{6}$ $\theta = 14.04^\circ$	1 1	4
	(b) $\sqrt{1.5^2 + 6^2} = 6.185$	2	

No.	Skema Pemarkahan Marking Scheme	Markah Marks	Markah Total Total Marks
4	Sofa $M = (5 \times 9^2) + (4 \times 9^1) + (7 \times 9^0) = 448$ Sofa $N = (2 \times 6^3) + (4 \times 6^2) + (4 \times 6^1) + (1 \times 6^0) = 601$ $\therefore$ Sofa $M$ lebih murah./Sofa $M$ is cheaper.	2 1	3
5	(a) $N \propto \frac{D}{P}$ $N = \frac{kD}{P}$ $480 = \frac{k(5\,000)}{80}$ $k = 7.68$ $N = \frac{7.68D}{P}$	1 1	4
	(b) $D = 75\,000, P = 80$ $N = \frac{(7.68)(75\,000)}{80} = 7\,200$	2	
6	(a) Gaji/Salary = RM56 000 Derma/Donation = RM200 Pendapatan bercukai/Chargeable income $= 56\,000 - 200 - 9\,000 - 1\,800 - 3\,000$ $= \text{RM}42\,000$	1 1	5
	(b) Kos perubatan selepas deduktibel/Medical cost after deductible $= 27\,000 - 2\,000$ $= \text{RM}25\,000$ Kos yang ditanggung oleh Athar/Cost borne by Athar $= \left(\frac{10}{100} \times 25\,000\right) + 2\,000$ $= \text{RM}4\,500$	2 1	
7	(a) $y = 3$	1	5
	(b) (i) $13 = \sqrt{(8-3)^2 + (2-h)^2}$ $169 = 25 + 4 - 4h + h^2$ $0 = h^2 - 4h - 140$ $0 = (h-14)(h+10)$ $h-14=0 \quad h+10=0$ $h=14 \quad h=-10$ $\therefore$ Koordinat rumah Liza ialah $(-10, 30)$ . Maka, $h$ adalah $-10$ . <i>The coordinate of Liza's house is <math>(-10, 30)</math>. Then, <math>h</math> is <math>-10</math>.</i>	1 1	
	(ii) $y = mx + c$ $m = \frac{8-3}{2-(-10)}$ $= \frac{5}{12}$ $3 = \frac{5}{12}(2) + c$ $c = \frac{13}{6}$ $y = \frac{5}{12}x + \frac{13}{6}$	1 1	
		1	

No.	Skema Pemarkahan Marking Scheme	Markah Marks	Markah Total Total Marks
8	$\frac{7+5}{x} = \frac{1}{3}$ $\frac{12}{x} = \frac{1}{3}$ <p>Jumlah murid/Number of students = <math>3 \times 12</math> = 36</p> <p>Bilangan murid yang lulus/Number of students who passed = <math>36 - 12</math> = 24</p> <p>Lelaki/Boys = <math>\frac{24}{3} \times 1</math> = 8</p> <p>Perempuan/Girls = <math>\frac{24}{3} \times 2</math> = 16</p> <p><math>\therefore x = 8, y = 16</math></p>	<p>1</p> <p>1</p> <p>1</p> <p>1</p>	<p>4</p>
9	<p>(a) Pendapatan/Income = 3 200 Perbelanjaan/Expenses = 1 950</p> <p>Baki/Balance = <math>3\ 200 - 1\ 950</math> = RM1 250</p> <p><math>14\ 400 \div 12</math> bulan/months = RM1 200</p> <p>Muaz dapat mencapai matlamat kewangannya kerana baki gajinya melebihi simpanan yang diperlukan untuk beliau membeli motosikal tersebut. <i>Muaz was able to achieve his financial goals because his remaining salary exceeded the savings required for him to buy the motorcycle.</i></p> <p>(b) Pendapatan/Income = 4 000 Perbelanjaan/Expenses = 3 200</p> <p>Aliran tunai positif/Positive cash flow = 1 850 Baki pendapatan/Balance income = <math>4\ 000 - 3\ 200</math> = 800</p> <p>Pendapatan yang diperoleh daripada kerja sambilan = <math>1\ 850 - 800</math> <i>Income earned from the part time job</i> = RM1 050</p>	<p>1</p> <p>1</p> <p>1</p> <p>1</p>	<p>4</p>
10	<p>(a) <math>\frac{(42 \times 3) + (47 \times 6) + (52 \times m) + (57 \times 16) + (62 \times 10) + (67 \times 4)}{3 + 6 + m + 16 + 10 + 4} = 55.6</math> <math>\frac{2\ 208 + 52m}{39 + m} = 55.6</math> <math>2\ 208 + 52m = 2\ 168.4 + 55.6m</math> <math>2\ 208 - 2\ 168.4 = 55.6m - 52m</math> <math>39.6 = 3.6m</math> <math>m = 11</math></p> <p>(b) <math>\sigma^2 =</math> <math>\frac{(3 \times 42^2) + (6 \times 47^2) + (11 \times 52^2) + (16 \times 57^2) + (10 \times 62^2) + (4 \times 67^2)}{3 + 6 + 11 + 16 + 10 + 4} - 55.6^2</math> <math>= \frac{156\ 670}{50} - 55.6^2</math> <math>= 42.04</math></p>	<p>2</p> <p>1</p> <p>2</p> <p>1</p>	<p>6</p>

No.	Skema Pemarkahan Marking Scheme	Markah Marks	Markah Total Total Marks
11	<p>(a) Lelayang <math>DEFG</math> dan <math>DABC</math>, segi tiga <math>EFJ</math> dan <math>ABJ</math>.  <i>Kite <math>DEFG</math> and <math>DABC</math>, triangle <math>EFJ</math> and <math>ABJ</math>.</i>            (Terima mana-mana jawapan yang munasabah)  <i>(Accept any reasonable answer)</i></p>	2	
	<p>(b)</p>	2	
	<p>(c) (i) <b>Q:</b> Pantulan pada garis <math>x = 3</math>.  <i>Reflection on line <math>x = 3</math>.</i></p> <p>(ii) <math>k = \frac{6}{3}</math>  <math>= 2</math></p> <p><b>P:</b> Pembesaran pada titik <math>J</math> dengan faktor skala, <math>k = 2</math>.  <i>Enlargement at point <math>J</math> with the scale factor, <math>k = 2</math>.</i></p>	2	9

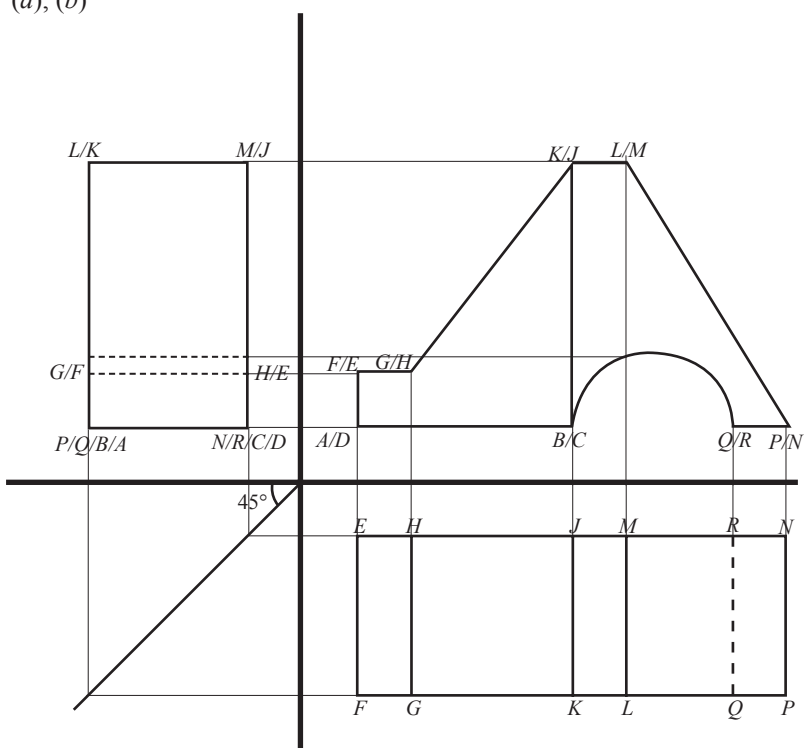
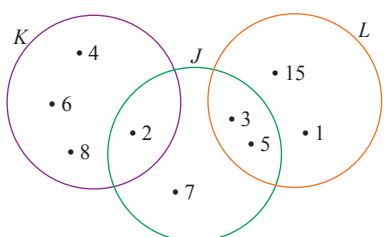
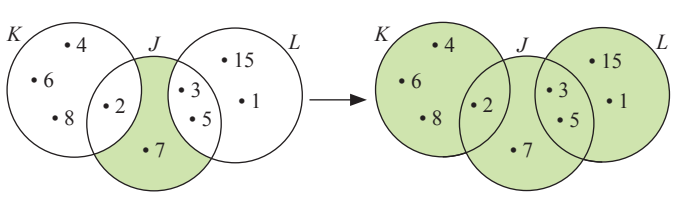
No.	Skema Pemarkahan Marking Scheme	Markah Marks	Markah Total Total Marks
12	<p>(a), (b)</p> 	<p>4</p> <p>5</p>	<p>9</p>
13	<p>(a) Joe = {2, 3, 5, 7}</p> <p>Karl = {2, 4, 6, 8}</p> <p>Liam = {1, 3, 5, 15}</p> <p>(b) (i)</p>  <p>(ii) <math>(K \cup L)' \rightarrow (K \cup L)' \cup J'</math></p> 	<p>1</p> <p>1</p> <p>1</p> <p>3</p> <p>2</p>	<p>8</p>

No.	Skema Pemarkahan Marking Scheme	Markah Marks	Markah Total Total Marks
14	<p>(a) <math>p = \text{piza/pizza}</math>, <math>c = \text{kek cawan/cup cake}</math></p> $3p + 6c = 45 \dots\dots\dots ①$ $7p = 45 + c$ $7p - c = 45 \dots\dots\dots ②$ $\begin{pmatrix} 3 & 6 \\ 7 & -1 \end{pmatrix} \begin{pmatrix} p \\ c \end{pmatrix} = \begin{pmatrix} 45 \\ 45 \end{pmatrix}$ $\begin{pmatrix} p \\ c \end{pmatrix} = \frac{1}{3(-1) - 6(7)} \begin{pmatrix} -1 & -6 \\ -7 & 3 \end{pmatrix} \begin{pmatrix} 45 \\ 45 \end{pmatrix}$ $= \frac{1}{-45} \begin{pmatrix} -1(45) + (-6)(45) \\ -7(45) + 3(45) \end{pmatrix}$ $= \frac{1}{-45} \begin{pmatrix} -315 \\ -180 \end{pmatrix}$ $= \begin{pmatrix} 7 \\ 4 \end{pmatrix}$ <p><math>p = 7, c = 4</math></p>	<p>1</p> <p>1</p> <p>2</p> <p>2</p>	
	<p>(b) Baucar ketiga/<i>Third voucher</i> = <math>125 - 45 - 45</math> = 35</p> $4p + 2c$ $= (4 \quad 2) \begin{pmatrix} p \\ c \end{pmatrix}$ $= (4 \quad 2) \begin{pmatrix} 7 \\ 4 \end{pmatrix}$ $= 4(7) + 2(4)$ $= 36$ <p>Nilai belian ialah RM36 manakala nilai baucar ialah RM35. <i>The purchase value is RM36 while the voucher value is RM35.</i> ∴ Nilai baucar tidak mencukupi./<i>Voucher value is insufficient.</i></p>	<p>1</p> <p>1</p> <p>1</p>	<p>9</p>

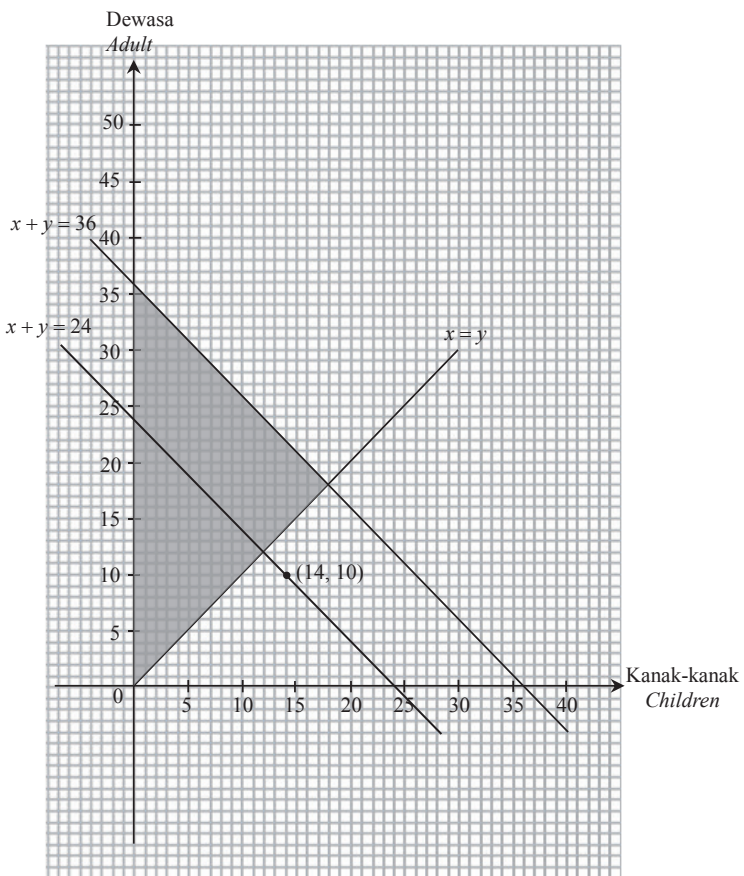
No.	Skema Pemarkahan Marking Scheme	Markah Marks	Markah Total Total Marks
15	<p>(a) <math>x + y \leq 36</math>  <math>x \leq y</math>            (b), (d)(ii)</p> 	<p>1</p> <p>1</p> <p>4</p>	
	<p>(c) Tidak kerana titik (14, 10) terletak di luar kawasan rantau berlorek.  <i>No because point (14, 10) lies outside the shaded region.</i></p>	2	
	<p>(d) (i) <math>x + y \leq 24</math></p> <p>(ii) Rujuk graf di atas./<i>Refer the above graph.</i></p>	<p>1</p> <p>1</p>	

10

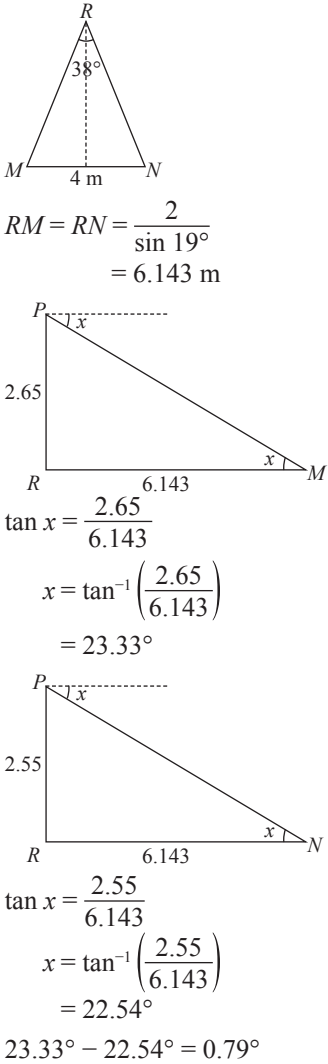
No.	Skema Pemarkahan Marking Scheme	Markah Marks	Markah Total Total Marks
16	(a) (i) $23 - 18 = 5$ minit/minutes	1	
	(ii) Laju purata/Average speed = $\frac{\text{Jumlah jarak/Total distance}}{\text{Jumlah masa/Total time}}$ $= \frac{10}{45}$ $= 0.22 \text{ km min}^{-1}$	1  1	
	(b) Protein = 250 Natrium/Sodium – kalsium/calcium, $(N - K) = 36^\circ$ Lemak/Fat = $11^\circ$  $N - K = 36^\circ$ ..... ① $11^\circ + 30^\circ + N + K + 209^\circ = 360^\circ$ ..... ②  $N = 36^\circ + K$ $11^\circ + 30^\circ + (36^\circ + K) + K + 209^\circ = 360^\circ$ $286^\circ + 2K = 360^\circ$ $K = 37^\circ$	1  1  1  1	
	(c)  $RM = RN = \frac{2}{\sin 19^\circ}$ $= 6.143 \text{ m}$  $\tan x = \frac{2.65}{6.143}$ $x = \tan^{-1}\left(\frac{2.65}{6.143}\right)$ $= 23.33^\circ$  $\tan x = \frac{2.55}{6.143}$ $x = \tan^{-1}\left(\frac{2.55}{6.143}\right)$ $= 22.54^\circ$  $23.33^\circ - 22.54^\circ = 0.79^\circ$	1          1  1	

No.	Skema Pemarkahan Marking Scheme	Markah Marks	Markah Total Total Marks
	<p>(d) <math>\bar{x}_S = \frac{254 + 251 + 256 + 260 + 253}{5}</math>  <math>= 254.8</math></p> <p><math>\sigma_S = \sqrt{\frac{254^2 + 251^2 + 256^2 + 260^2 + 253^2}{5} - (254.8)^2}</math>  <math>= 3.059</math></p> <p><math>\bar{x}_T = \frac{252 + 255 + 258 + 254 + 255}{5}</math>  <math>= 254.8</math></p> <p><math>\sigma_T = \sqrt{\frac{252^2 + 255^2 + 258^2 + 254^2 + 255^2}{5} - (254.8)^2}</math>  <math>= 1.939</math></p> <p>Raket T. Nilai sisihan piawai yang lebih kecil menunjukkan laju bola tangkis lebih konsisten apabila menggunakan raket T.  <i>Racquet T. A smaller standard deviation value indicates that the shuttlecock speed is more consistent when using racquet T.</i></p>	<p>1</p> <p>1</p> <p>1</p> <p>1</p> <p>1</p>	<p>15</p>
17	<p>(a) (i) <math>5 : 35</math>  <math>= \frac{5}{5} : \frac{35}{5}</math>  <math>= 1 : 7</math></p> <p>(ii) <math>\frac{7}{35} = \frac{1}{5}</math></p> <p>(b) <math>g = \text{guru/teacher}</math>, <math>m = \text{murid/pupil}</math></p> <p><math>g = m + 40</math> ..... ①  <math>5g + 35m = 3\,000</math> ..... ②</p> <p><math>5(m + 40) + 35m = 3000</math>  <math>5m + 200 + 35m = 3000</math>  <math>40m = 3\,000 - 200</math>  <math>m = 70</math></p> <p><math>g = 70 + 40</math>  <math>g = 110</math></p> <p>Yuran yang perlu dibayar oleh seorang murid ialah RM70, manakala seorang guru ialah RM110.  <i>The fee that has to be paid by a student is RM70, while a teacher is RM110.</i></p> <p>(c) (i) Graf laju-masa : jarak = luas bawah graf  <i>Graph speed-time : distance = area under a graph</i></p> <p>Luas bawah graf/Area under a graph  <math>= \left(\frac{1}{2} \times 90 \times \frac{[(36-8)+40]}{60}\right) + \left(\frac{1}{2} \times 80 \times \frac{[(200-75)+(191-79)]}{60}\right)</math>  <math>= 51 + 158</math>  <math>= 209 \text{ km}</math></p>	<p>1</p> <p>2</p> <p>1</p> <p>1</p> <p>1</p> <p>1</p> <p>1</p>	

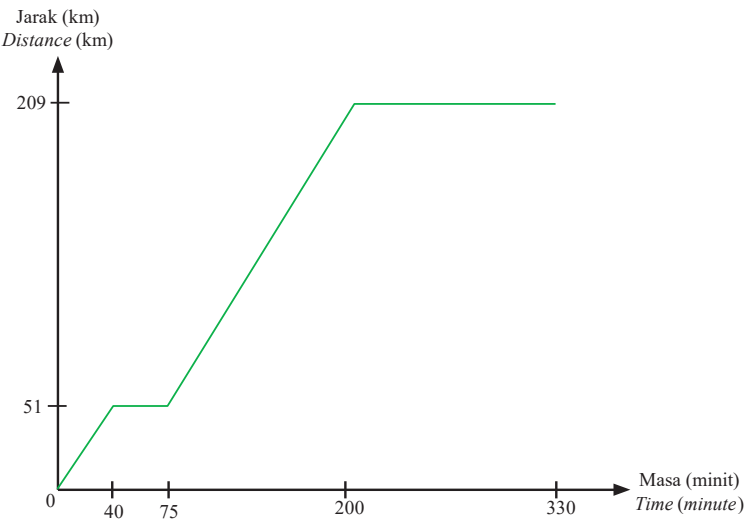
No.	Skema Pemarkahan Marking Scheme	Markah Marks	Markah Total Total Marks
	<p>(ii)</p> 	3	
	<p>(d) Cikgu Linda: <math>P \rightarrow T \rightarrow S \rightarrow U \rightarrow R \rightarrow Q</math>  <math>= 15 + 21 + 20 + 11 + 9</math>  <math>= 76</math></p> <p>Cikgu Kumar: <math>P \rightarrow Q \rightarrow R \rightarrow U \rightarrow S \rightarrow T</math>  <math>= 13 + 9 + 11 + 20 + 21</math>  <math>= 74</math></p> <p>Pendapat Cikgu Kumar lebih baik kerana tempoh masa untuk sampai lebih pendek iaitu 74 minit. Ini sesuai dengan matlamat mereka yang mahu menjimatkan masa perjalanan.  <i>Cikgu Kumar's opinion is better because the arrival time is shorter which is 74 minutes. This suits the purpose of those who want to save travel time.</i></p>	1  1  1	15

KERTAS 1

1 B

$$\begin{aligned} 3x^2 + 8x - 3 &= 0 \\ (3x - 1)(x + 3) &= 0 \\ 3x - 1 &= 0 & x + 3 &= 0 \\ x &= \frac{1}{3} & x &= -3 \end{aligned}$$

2 B

$$\begin{aligned} 6x^2 - 7x - 49 &= 0 \\ (2x - 7)(3x + 7) &= 0 \end{aligned}$$

3 D

$$\begin{aligned} -2(6y + 3) &< 3(4 - 2y) \\ -12y - 6 &< 12 - 6y \\ -12y + 6y &< 12 + 6 \\ -6y &< 18 \\ y &> \frac{18}{(-6)} \\ y &> -3 \end{aligned}$$

4 A

Logam berbentuk sfera = 30  
*Sphere-shaped metals*

$$\begin{aligned} \text{Isi padu sfera} &= \frac{4}{3} \pi r^3 \\ \text{Volume of sphere} &= 30 \times \frac{4}{3} \times \frac{22}{7} \times 35^3 \\ &= 5\,390\,000 \end{aligned}$$

$$\begin{aligned} \text{Isi padu kon} &= \frac{5\,390\,000}{70} \\ \text{Volume of cone} &= 77\,000 \\ &= 7.7 \times 10^4 \end{aligned}$$

5 D

$$\begin{aligned} 0.17056 &= 1.7056 \times 10^{-1} \\ &= m \times 10^n \\ m &= 1.7056, n = -1 \end{aligned}$$

6 A

$$\begin{aligned} \angle ABD &= \frac{180^\circ - 58^\circ}{2} \\ &= 61^\circ \\ \angle ABD &= \angle EBC = 61^\circ \\ \angle FEC &= \angle ECB = 92^\circ \\ x &= 180^\circ - 61^\circ - 92^\circ \\ &= 27^\circ \end{aligned}$$

7 A

$$\begin{aligned}4(4^x) &= 2^3(\sqrt{4}) \\ 2^2(2^{2x}) &= 2^3(2^1) \\ 2 + 2x &= 3 + 1 \\ x &= \frac{4-2}{2} \\ &= 1\end{aligned}$$

8 A

$$\begin{aligned}\angle ODC &= \frac{180^\circ - 100^\circ}{2} \\ &= 40^\circ \\ \angle CBD &= \frac{100^\circ}{2} \\ &= 50^\circ \\ \angle DCB &= \angle DBE = 70^\circ \\ \angle OCB &= 70^\circ - 40^\circ \\ &= 30^\circ \\ \angle CDB &= 180^\circ - 70^\circ - 50^\circ \\ &= 60^\circ \\ y &= 60^\circ - 40^\circ \\ &= 20^\circ\end{aligned}$$

9 D

Bergerak ke kanan 3 petak/Move to right 3 boxes = 3

Bergerak ke atas 1 petak/Move to above 1 box = 1

Translasi/Translation  $\begin{pmatrix} 3 \\ 1 \end{pmatrix}$

10 B

7, 3, 4, 9, 2, 1,  $r$   
Mod/Mode = 4  
 $r = 4$

11 D

$$\begin{aligned}\left(\frac{5 \times 4x}{4x \times 4x}\right) - \frac{10-x}{16x^2} &= \frac{20x}{16x^2} - \frac{10-x}{16x^2} \\ &= \frac{20x - (10-x)}{16x^2} \\ &= \frac{20x - 10 + x}{16x^2} \\ &= \frac{21x - 10}{16x^2}\end{aligned}$$

12 B

$$\begin{aligned}3y &\leq 15 & 19 - 4y &< 11 \\ y &\leq \frac{15}{3} & -4y &< 11 - 19 \\ y &\leq 5 & y &> \frac{-8}{-4} \\ & & y &> 2\end{aligned}$$

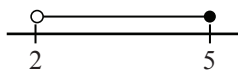

$\therefore y = 3, 4, 5$

13 D

$$U = \{L, O, V, E\}$$

$$\text{Subset} = 2^n$$

$$n = 4$$

$$\therefore 2^4 = 16$$

14 A

$$2a^2 - 5a - 3 = 0$$

$$2a + 1 \rightarrow +a$$

$$a - 3 \rightarrow \frac{-6a}{-5a}$$

$$(2a + 1)(a - 3) = 0$$

15 B

$$343\sqrt{c^6} = (9a + 6bc)^3$$

$$\sqrt{c^6} = \frac{(9a + 6bc)^3}{343}$$

$$c^6 = \left[ \frac{(9a + 6bc)^3}{343} \right]^2$$

$$c = \left[ \frac{(9a + 6bc)^6}{343^2} \right]^{\frac{1}{6}}$$

$$c = \frac{9a + 6bc}{343^{\frac{1}{3}}}$$

$$c = \frac{9a + 6bc}{7}$$

$$7c = 9a + 6bc$$

$$7c - 6bc = 9a$$

$$c(7 - 6b) = 9a$$

$$c = \frac{9a}{7 - 6b}$$

16 D

$$\text{Satu sudut pedalaman pentagon/An interior angle of pentagon} = \frac{(5 - 2) \times 180^\circ}{5}$$

$$= 108^\circ$$

$$x = \frac{180^\circ - 108^\circ}{2}$$

$$= 36^\circ$$

$$\text{Satu sudut heksagon/An angle of hexagon} = \frac{(6 - 2) \times 180^\circ}{6}$$

$$= 120^\circ$$

$$y = 120^\circ - 108^\circ$$

$$= 12^\circ$$

$$y + x = 12^\circ + 36^\circ$$

$$= 48^\circ$$

17 C

$$\begin{aligned}\text{Isi padu tin/Volume of a can} &= \pi \times 8^2 \times 14 \\ &= 896\pi\end{aligned}$$

$$\begin{aligned}\text{Isi padu sup cendawan di dalam periuk/Volume of a mushroom soup in a pot} \\ &= 892\pi \times 2 \\ &= 1\,792\pi\end{aligned}$$

$$\begin{aligned}\text{Isi padu sup cendawan di dalam setiap mangkuk/Volume of a mushroom soup in a bowl} \\ &= \frac{1\,792\pi}{16} \\ &= 112\pi\end{aligned}$$

18 A

Luas kawasan berlorek = luas trapezium  $ABCD$  – luas segi tiga  $ABE$

*Area of shaded region = area of trapezium  $ABCD$  – area of triangle  $ABE$*

$$\begin{aligned}AE &= \sqrt{13^2 - 12^2} \\ &= 5\end{aligned}$$

Luas kawasan berlorek/*Area of the shaded region*

$$\begin{aligned}&= \left[ \frac{1}{2} \times (14+16) \times 13 \right] - \left[ \frac{1}{2} \times 12 \times 5 \right] \\ &= 195 - 30 \\ &= 165\end{aligned}$$

19 C

$$\begin{aligned}\frac{8^{2m-4} \times 4^{m+1}}{2^{14m-7} \times 64^{-m}} &= \frac{(2^3)^{2m-4} \times (2^2)^{m+1}}{2^{14m-7} \times (2^6)^{-m}} \\ &= \frac{2^{6m-12} \times 2^{2m+2}}{2^{14m-7} \times 2^{-6m}} \\ &= \frac{2^{6m-12+2m+2}}{2^{14m-7+(-6m)}} \\ &= \frac{2^{8m-10}}{2^{8m-7}} \\ &= 2^{8m-10-(8m-7)} \\ &= 2^{8m-10-8m+7} \\ &= 2^{-3} \\ &= \frac{1}{2^3} \\ &= \frac{1}{8}\end{aligned}$$

20 B

$$m_{PS} = \frac{3}{4}$$

$$T(-8, y_1)$$

$$P(0, y_2)$$

$$R(-8, -2)$$

$$\begin{aligned}\frac{y_2 - 0}{0 - (-8)} &= \frac{3}{4} \\ y_2 &= 6\end{aligned}$$

$$PS = TR$$

$$\sqrt{(6-0)^2 + [0 - (-8)]^2} = \sqrt{[y_1 - (-2)]^2 + [-8 - (-8)]^2}$$

$$100 = (y+2)^2$$

$$y+2 = 10$$

$$y = 8$$

$$T(-8, 8)$$

21 B

Mangga : Epal = 7 : 5

Mango : Apple

Epal/Apples = 15

Mangga tidak elok/Rotten mangoes = 5

5 bahagian/parts = 15

$$7 \text{ bahagian/parts} = \frac{15}{5} \times 7$$

$$= 21$$

∴ Mangga/Mangoes = 21

Mangga yang elok/Good mangoes = 21 - 5  
= 16

22 A

A : Kuasa tertinggi/Highest exponent = 2

Bilangan pemboleh ubah/Number of variables = 1 (Benar/True)

B : Bilangan pemboleh ubah/Number of variables = 2

(Tidak berkenaan/Not applicable)

C : Kuasa tertinggi/Highest exponent = -2

(Tidak berkenaan/Not applicable)

D : Kuasa tertinggi/Highest exponent = 1

23 A

$$I_5 = 265_8$$

$$265_8 = (2 \times 8^2) + (6 \times 8^1) + (5 \times 8^0)$$

$$= 128 + 48 + 5$$

$$= 181$$

5	181		
5	36	baki/remainder	1
5	7	baki/remainder	1
5	1	baki/remainder	2
5	0	baki/remainder	1

$$= 1211_5$$

$$\therefore \overline{I} = 1211$$

24 D

$$\left(\frac{-6a^3b^{-\frac{1}{6}}}{c^2}\right)^3 \times b^{\frac{1}{3}}c^3 = \frac{(-6)^3a^9b^{-\frac{1}{2}}}{c^6} \times b^{\frac{1}{3}}c^3$$

$$= \frac{-216a^9}{c^3}$$

25 A

Jika  $p$ , maka  $q$ .

If  $p$ , then  $q$ .

$p$  = antejadian/antecedent

$q$  = akibat/consequent

Akibat/Consequent:  $n = 343$

26 C

$P \cap (Q \cup R)'$ :

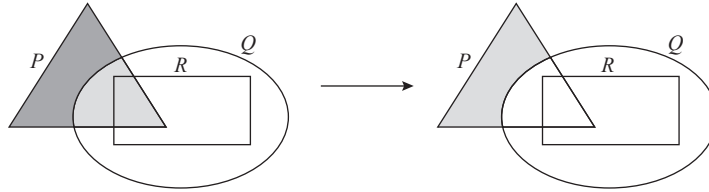

27 B

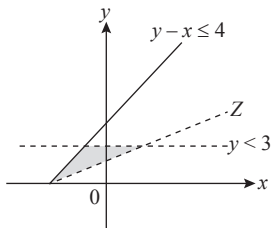

$$m_z = \frac{2-0}{0-(-4)}$$

$$= \frac{1}{2}$$

$$y = mx + c$$

$$y = \frac{1}{2}x + 2$$

$$Z: y > \frac{1}{2}x + 2$$

$$2y > x + 4$$

28 B

Kadar perubahan laju = kecerunan

Rate of change of speed = gradient

$$\frac{v-20}{14-8} = 1\frac{2}{3}$$

$$v = \left(\frac{5}{3} \times 6\right) + 20$$

$$= 30 \text{ m s}^{-1}$$

29 C

Min/Mean = 10

$$\frac{(10+x) + 5x + 6 + 9 + 14 + (2x+5)}{6} = 10$$

$$8x + 44 = 60$$

$$x = \frac{60-44}{8}$$

$$x = 2$$

$$10 + x = 10 + 2$$

$$= 12$$

$$5x = 5(2)$$

$$= 10$$

$$2x + 5 = 2(2) + 5$$

$$= 9$$

Data: 6, 9, 9, 10, 12, 14

$$\text{Median} = \frac{9 + 10}{2} = 9.5$$

$$\text{Mod/Mode} = 9$$

$$9.5 + 9 = 18.5$$

**30 B**

$$\text{Epal/Apples} = 40$$

$$\text{Limau/Limes} = 24$$

$$\text{Manggis/Mangosteen} = 16$$

$$\begin{aligned} \text{Kebarangkalian/Probability} &= \frac{40 + 16}{40 + 24 + 16} \\ &= \frac{56}{80} \\ &= \frac{7}{10} \end{aligned}$$

**31 D**

$$7 + 5 = 12 \text{ biji bola biru/blue balls}$$

$$7 + 5 = 12 \text{ biji bola merah jambu/pink balls}$$

$$\text{Bilangan bola hijau/Number of green balls} = x + 6$$

$$\text{Kebarangkalian bola hijau/Probability of green balls} = \frac{1}{3}$$

$$\frac{x + 6}{12 + 12 + x + 6} = \frac{1}{3}$$

$$\frac{x + 6}{30 + x} = \frac{1}{3}$$

$$3x + 18 = 30 + x$$

$$3x - x = 30 - 18$$

$$2x = 12$$

$$x = 6$$

**32 B**

$$a \propto \frac{b}{c}$$

$$a = \frac{6}{5}, b = 4, c = 20$$

$$a = k \frac{b}{c}$$

$$\frac{6}{5} = k \left( \frac{4}{20} \right)$$

$$k = 6$$

$$a = \frac{6b}{c}, a = \frac{3}{2}, b = 7$$

$$\frac{3}{2} = \frac{6(7)}{c}$$

$$c = \frac{42 \times 2}{3}$$

$$= 28$$

33 A

$$A \propto \sqrt[3]{F}, A = 56, F = 512$$

$$A = k\sqrt[3]{F}$$

$$56 = k\sqrt[3]{512}$$

$$k = 7$$

$$A = 7\sqrt[3]{F}, F = 9\,261$$

$$A = 7\sqrt[3]{9\,261}$$

$$A = 147$$

34 D

$$4(y - 2) - (1 - 2y)^2 = 0$$

$$4y - 8 - (1 - 4y + 4y^2) = 0$$

$$4y - 8 - 1 + 4y - 4y^2 = 0$$

$$-4y^2 + 8y - 9 = 0$$

35 D

Secara umumnya, tujuan mendapatkan insurans adalah seperti berikut:

*In general, the purpose of obtaining insurance is as follows:*

- Sebagai bantuan kewangan kepada keluarga sekiranya anda hilang upaya, menghadapi penyakit kritikal atau meninggal dunia.

*As a financial assistance to the family in the event of your disability, critical illness or death.*

- Mengurus perbelanjaan hidup, hutang dan komitmen sekiranya anda tidak mampu bekerja.

*Manage living expenses, debts and commitments if you are unable to work.*

- Bayaran perbelanjaan perubatan rawatan yang tinggi.

*Payment of high medical treatment expenses.*

- Sebagai pampasan terhadap kerugian yang dialami.

*As compensation for losses suffered.*

36 C

$$\begin{bmatrix} 2 & 1 \\ 3 & -5 \end{bmatrix} - M = \begin{bmatrix} 2 & 3 \\ -1 & 6 \end{bmatrix}$$

$$M = \begin{bmatrix} 2 & 1 \\ 3 & -5 \end{bmatrix} - \begin{bmatrix} 2 & 3 \\ -1 & 6 \end{bmatrix}$$

$$= \begin{bmatrix} 2-2 & 1-3 \\ 3-(-1) & -5-6 \end{bmatrix}$$

$$= \begin{bmatrix} 0 & -2 \\ 4 & -11 \end{bmatrix}$$

37 C

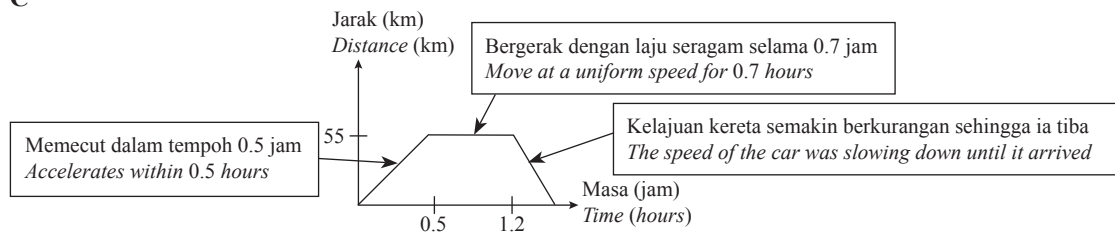

38 A

$$\begin{aligned}SR &= \sqrt{10^2 - 6^2} \\ &= 8 \\ \sin y &= -\frac{8}{10} \\ &= -\frac{4}{5}\end{aligned}$$

39 B

$$\begin{aligned}\text{Pinjaman/Loan} &= \frac{90}{100} \times 360\,000 \\ &= \text{RM}324\,000\end{aligned}$$

$$\begin{aligned}\text{Jumlah ansuran/Amount of installment} &= 25 \times 12 \times 1\,836 \\ &= \text{RM}550\,800\end{aligned}$$

$$\begin{aligned}\text{Faedah/Interest} &= \text{RM}550\,800 - \text{RM}324\,000 \\ &= \text{RM}226\,800\end{aligned}$$

$$\begin{aligned}25 \times \frac{x}{100} \times 324\,000 &= 226\,800 \\ x &= 2.8\end{aligned}$$

40 B

$$\begin{aligned}n \text{ kos}/\cos \theta &= \frac{1}{2} \\ \theta &= 60^\circ \\ \tan 60^\circ &= \frac{x}{y} \\ x &= y \tan 60^\circ\end{aligned}$$

## KERTAS 2

### Bahagian A

#### Section A

1

$$\begin{aligned}-\frac{2}{3-5y} &= \frac{y}{3-2y} \\ -2(3-2y) &= y(3-5y) \\ -6+4y &= 3y-5y^2 \\ 5y^2+4y-3y-6 &= 0 \\ 5y^2+y-6 &= 0 \\ (5y+6)(y-1) &= 0 \\ 5y+6 &= 0 \\ 5y &= -6 \\ y &= -\frac{6}{5} \\ y-1 &= 0 \\ y &= 1\end{aligned}$$

2 (a) (i) Bukan pernyataan

*Not a statement*

(ii) Pernyataan

*Statement*

(b) Jika  $M \cup N = M$ , maka  $N \subset M$ .  
 If  $M \cup N = M$ , then  $N \subset M$ .

Jika  $N \subset M$ , maka  $M \cup N = M$ .  
 If  $N \subset M$ , then  $M \cup N = M$ .

3 (a)

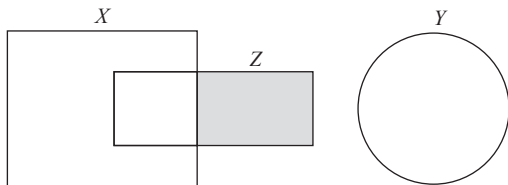

(b)

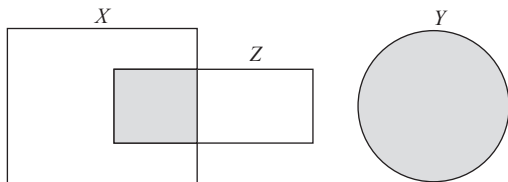

$$\begin{aligned}
 4 \quad & 2x - 3y = 6 \quad \text{..... ①} \\
 & 3x - 7y = 19 \quad \text{..... ②} \\
 & \text{①} \times 3 : 6x - 9y = 18 \quad \text{..... ③} \\
 & \text{②} \times 2 : 6x - 14y = 38 \quad \text{..... ④} \\
 & \text{③} - \text{④} : 5y = -20 \\
 & \quad \quad y = -4 \\
 & 6x - 9(-4) = 18 \\
 & 6x + 36 = 18 \\
 & 6x = -18 \\
 & \quad \quad x = -3
 \end{aligned}$$

5 (a) (i)  $V = \{J, K, L, M, N, O\}$   
 $n(V) = 6$

(ii)  $E = \{(J, K), (J, M), (M, L), (L, N), (K, N), (N, O), (M, O), (M, N)\}$   
 $n(E) = 8$

(iii)  $2 \times n(E) = 16$

(b) Terima semua gambar rajah pokok yang sesuai.  
 Accept all suitable tree diagrams.

6 (a) Kadar perubahan laju/Rate of change of speed =  $\frac{(40 - 0)}{5 - 0} \text{ m s}^{-2}$   
 $= \frac{40}{5} \text{ m s}^{-2}$   
 $= 8 \text{ m s}^{-2}$

(b) Jarak/Distance =  $\left(\frac{1}{2} \times 5 \times 40\right) + \left[\frac{1}{2} \times (u + 40) \times 8\right] + (u \times 7)$   
 $392 \text{ m} = 100 + (4u + 160) + 7u$   
 $392 \text{ m} = 260 + 11u$   
 $132 \text{ m} = 11u$   
 $u = 12 \text{ m s}^{-1}$

7 (a)  $\{(J, 1), (J, 2), (J, 3), (J, 4), (E, 1), (E, 2), (E, 3), (E, 4), (S, 1), (S, 2), (S, 3), (S, 4)\}$

(b)  $\frac{1}{3} \times \frac{2}{4} = \frac{2}{12} = \frac{1}{6}$

8 Isi padu piramid/*Volume of pyramid*  $= \frac{1}{3} \times (5 \times 5) \times 12$

$$= 100 \text{ cm}^3$$

Isi padu kuboid/*Volume of cuboid*  $= p \times l \times t$

$$= 5 \times 5 \times t$$

$$= 25t$$

Isi padu gabungan pepejal/*Volume of the composite solid*  $= 100 + 25t$

$$400 = 100 + 25t$$

$$25t = 300$$

$$t = 12 \text{ cm}$$

9 (a)  $y = mx + c, m = -2$

$$6 = -2(8) + c$$

$$6 = -16 + c$$

$$c = 22$$

$\therefore$  Persamaan garis lurus  $ST$  ialah  $y = -2x + 22$ .

*The equation of the straight line  $ST$  is  $y = -2x + 22$ .*

(b)  $y = mx + c$

$$0 = -2(x) + 22$$

$$2x = 22$$

$$x = 11$$

$\therefore$  Pintasan- $x$  bagi garis lurus  $JK$  ialah  $x = 11$ .

*x-intercept of the straight line  $JK$  is  $x = 11$ .*

10 (a) Perimeter seluruh rajah/*Perimeter of the whole diagram*

$$= \left( \frac{120^\circ}{360^\circ} \times 2 \times \frac{22}{7} \times 14 \right) + 7 + 7 + \left( \frac{240^\circ}{360^\circ} \times 2 \times \frac{22}{7} \times 7 \right)$$

$$= 29.33 + 7 + 7 + 29.33$$

$$= 72.66 \text{ cm}$$

(b) Luas kawasan berlerek/*Area of the shaded region*

$$= \frac{240^\circ}{360^\circ} \times \frac{22}{7} \times 7^2$$

$$= 102.67 \text{ cm}^2$$

**Bahagian B**  
**Section B**

11 (a) (i)

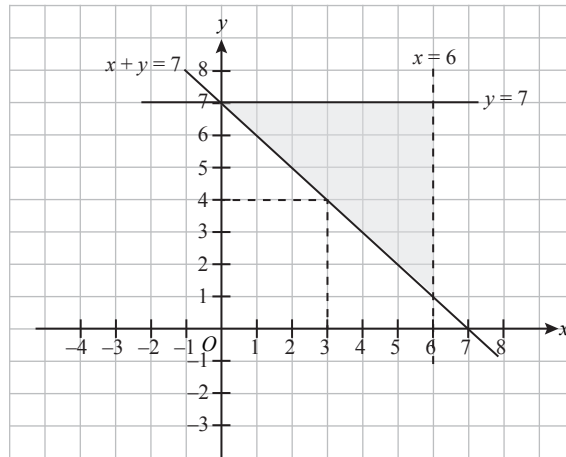

(a) (ii)  $y = 4$

(b) (i)  $x + y = 7$   
 $12x + 8y = 68$

(ii)  $\begin{pmatrix} 1 & 1 \\ 12 & 8 \end{pmatrix} \begin{pmatrix} x \\ y \end{pmatrix} = \begin{pmatrix} 7 \\ 68 \end{pmatrix}$

$$\begin{pmatrix} x \\ y \end{pmatrix} = \frac{1}{8-12} \begin{pmatrix} 8 & -1 \\ -12 & 1 \end{pmatrix} \begin{pmatrix} 7 \\ 68 \end{pmatrix}$$

$$\begin{pmatrix} x \\ y \end{pmatrix} = \frac{1}{-4} \begin{pmatrix} 56 - 68 \\ -84 + 68 \end{pmatrix}$$

$$\begin{pmatrix} x \\ y \end{pmatrix} = -\frac{1}{4} \begin{pmatrix} -12 \\ -16 \end{pmatrix}$$

$$\begin{pmatrix} x \\ y \end{pmatrix} = \begin{pmatrix} 3 \\ 4 \end{pmatrix}$$

Jumlah buku matematik = 3  
*Total of mathematics books*

Jumlah buku sains = 4  
*Total of science books*



(b)

<b>Pendapatan dan Perbelanjaan</b> <i>Income and Expenses</i>	<b>Pelan Kewangan</b> <i>Financial Plan</i> <b>(RM)</b>	<b>Aliran Tunai Sebenar</b> <i>Actual Cash Flow</i> <b>(RM)</b>
Pendapatan bersih Encik Kumaran <i>Net income Mr. Kumaran</i>	6 850	6 850
Jumlah perndapatan bulanan <i>Total monthly income</i>	6 850	6 850
Tolak simpanan dana kecemasan <i>Minus savings for emergency fund</i>	1 027.50	1 027.50
Baki pendapatan <i>Income balance</i>		5 822.50
<b>Tolak perbelanjaan tetap bulanan</b> <i>Minus monthly fixed expenses</i>		
Ansuran pinjaman perumahan <i>Housing loan instalment</i>	1 350	1 350
Ansuran pinjaman kereta <i>Car loan instalment</i>	600	600
Jumlah perbelanjaan tetap bulanan <i>Total monthly fixed expenses</i>		1 950
<b>Tolak perbelanjaan tidak tetap bulanan</b> <i>Minus monthly variable expenses</i>		
Barang runcit dan bil utiliti <i>Groceries and utility bills</i>	450	450
Petrol	300	300
Anak-anak <i>Children</i>	200	200
Makanan <i>Food</i>	1 000	1 000
Ibu bapa <i>Parents</i>	600	600
Jumlah perbelanjaan tidak tetap bulanan <i>Total monthly variable expenses</i>		2 550
Pendapatan lebihan <i>Surplus of income</i>		1 322.50

(c) Simpanan dalam 6 bulan/*Savings in 6 months* =  $RM1\ 322.50 \times 6$   
= RM7 935

RM7 935 > RM4 500

Jadi, matlamat jangka pendek boleh dicapai/*Hence, short term goal can be achieved.*

Simpanan dalam 5 tahun/*Savings in 5 years* =  $RM1\ 322.50 \times 12 \times 5$   
= RM79 350

Simpanan bersih/*Net savings* =  $RM79\ 350 - RM4\ 500$   
= RM74 850

10% duit pendahuluan/*10% down payment* = RM49 500

RM74 850 > RM49 500

Jadi, matlamat jangka panjang boleh dicapai.

*Hence, long term goal can be achieved.*

$$14 \text{ (a)} \begin{bmatrix} 3 & 2 & p \\ -3 & 4 & 0 \end{bmatrix} \begin{bmatrix} -1 & 2 \\ 2 & q \\ 5 & -4 \end{bmatrix} = \begin{bmatrix} -9 & r \\ 11 & 14 \end{bmatrix}$$

$$\begin{bmatrix} -3 + 4 + 5p & 6 + 2q - 4p \\ 3 + 8 & -6 + 4q \end{bmatrix} = \begin{bmatrix} -9 & r \\ 11 & 14 \end{bmatrix}$$

$$\begin{aligned} 1 + 5p &= -9 & -6 + 4q &= 14 \\ 5p &= -10 & 4q &= 20 \\ p &= -2 & q &= 5 \end{aligned}$$

$$\begin{aligned} 6 + 2(5) - 4(-2) &= r \\ 6 + 10 + 8 &= r \\ r &= 24 \end{aligned}$$

$$p = -2, q = 5, r = 24$$

$$(b) \text{ (i)} \quad AA^{-1} = I$$

$$\begin{aligned} \frac{1}{m} &= \frac{1}{4(-3) - 4(-5)} \\ &= \frac{1}{-12 + 20} \\ &= \frac{1}{8} \\ \therefore m &= 8 \end{aligned}$$

$$(ii) \quad \begin{aligned} 4x + 4y &= -4 \\ -5x - 3y &= -1 \end{aligned}$$

$$\begin{aligned} \begin{bmatrix} 4 & 4 \\ -5 & -3 \end{bmatrix} \begin{bmatrix} x \\ y \end{bmatrix} &= \begin{bmatrix} -4 \\ -1 \end{bmatrix} \\ \begin{bmatrix} x \\ y \end{bmatrix} &= \frac{1}{-12 - (-20)} \begin{bmatrix} -3 & -4 \\ 5 & 4 \end{bmatrix} \begin{bmatrix} -4 \\ -1 \end{bmatrix} \\ &= \frac{1}{8} \begin{bmatrix} 12 + 4 \\ -20 + (-4) \end{bmatrix} \\ &= \frac{1}{8} \begin{bmatrix} 16 \\ -24 \end{bmatrix} \\ &= \begin{bmatrix} 2 \\ -3 \end{bmatrix} \end{aligned}$$

$$\therefore x = 2, y = -3$$

15 (a) (i) Transformasi **G** ialah pantulan pada garis  $x = 1$ .  
*Transformation G is a reflection in the line  $x = 1$ .*

(ii) Transformasi **F** ialah pembesaran pada pusat  $T(4, 8)$  dengan faktor skala 3.  
*Transformation F is an enlargement at center  $T(4, 8)$  with a scale factor of 3.*

$$\begin{aligned} (b) \text{ Luas } PQRST / \text{Area of } PQRST &= 30 \text{ cm}^2 \\ \text{Luas } ABCDT / \text{Area of } ABCDT &= 3^2 \times 30 \\ &= 9 \times 30 \\ &= 270 \text{ cm}^2 \end{aligned}$$

Luas kawasan berlorek/Area of the shaded region

$$= 270 - 30$$

$$= 240 \text{ cm}^2$$

### Bahagian C

#### Section C

16 (a) (i)

Jisim (kg) Mass (kg)	Kekerapan Frequency
40 – 49	4
50 – 59	6
60 – 69	5
70 – 79	8
80 – 89	6
90 – 99	6

(ii) 70 – 79

(iii)

Jisim (kg) Mass (kg)	Kekerapan, $f$ Frequency, $f$	Titik tengah, $x$ Midpoint, $x$	$fx$	$fx^2$
40 – 49	4	44.5	178	7 921
50 – 59	6	54.5	327	17 821.5
60 – 69	5	64.5	322.5	20 801.25
70 – 79	8	74.5	596	44 402
80 – 89	6	84.5	507	42 841.5
90 – 99	6	94.5	567	53 581.5
	$\Sigma f = 35$		$\Sigma fx = 2 497.5$	$\Sigma fx^2 = 187 368.75$

Sisihan piawai/Standard deviation

$$= \sqrt{\frac{187\,368.75}{35} - \left(\frac{2\,497.5}{35}\right)^2}$$

$$= 16.173$$

(b) (i)

Jisim (kg) Mass (kg)	Sempadan atas Upper boundary	Kekerapan Frequency	Kekerapan longgokan Cumulative frequency
30 – 39	39.5	0	0
40 – 49	49.5	4	4
50 – 59	59.5	6	10
60 – 69	69.5	5	15
70 – 79	79.5	8	23
80 – 89	89.5	6	29
90 – 99	99.5	6	35

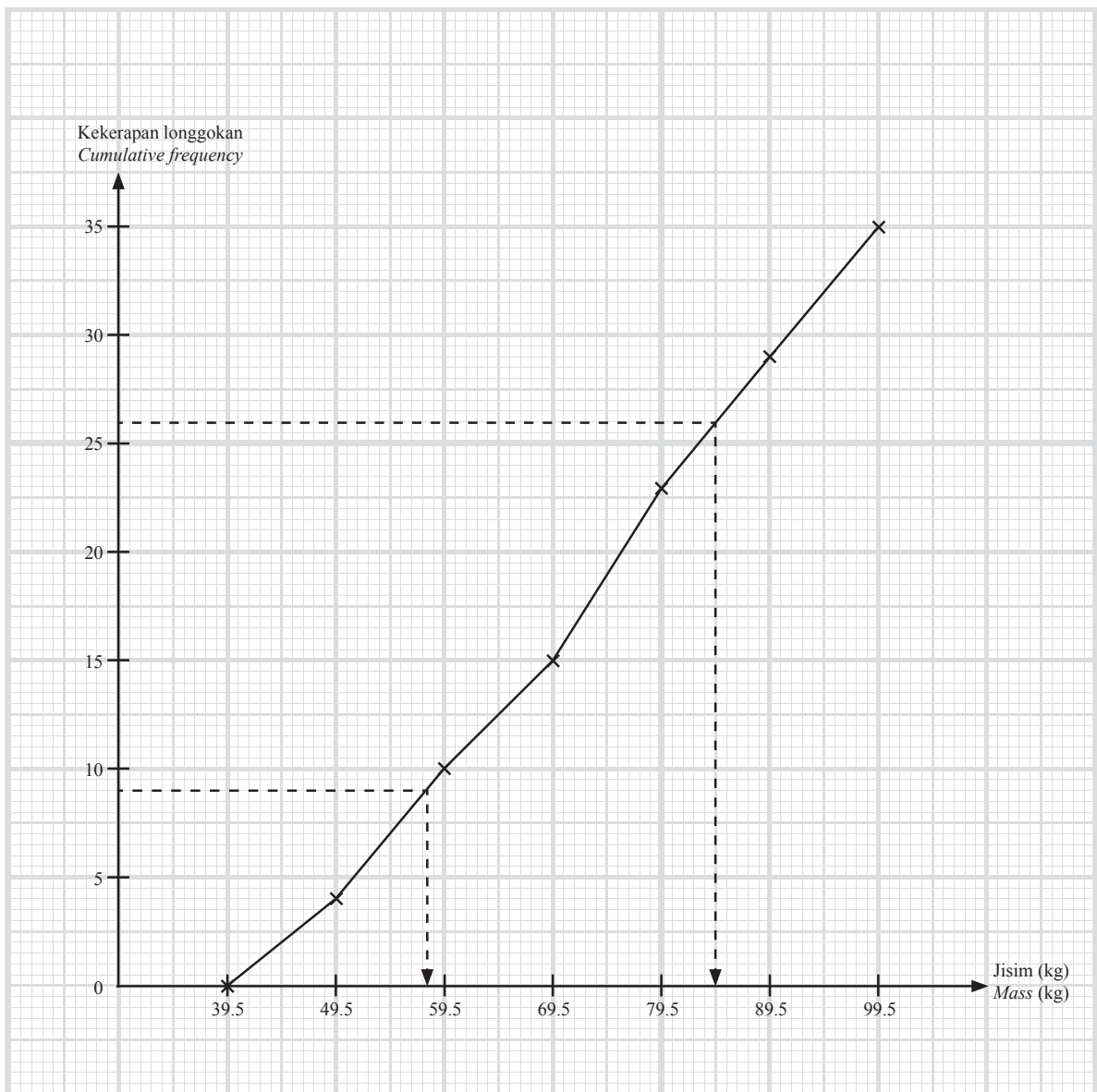

$$(ii) Q_1 = \frac{1}{4} \times 35 = 8.75 \approx 9$$

Daripada graf,  $Q_1 = 58$

From the graph

$$Q_3 = \frac{3}{4} \times 35 = 26.25 \approx 26$$

Daripada graf,  $Q_3 = 84.5$

From the graph

$$\text{Julat antara kuartil} = Q_3 - Q_1$$

Interquartile range

$$= 84.5 - 58$$

$$= 26.5$$

(iii) Bilangan murid dalam selang kelas  $90 - 99 = 6$  murid

*Number of pupils in the interval class  $90 - 99 = 6$  pupils*

$$\begin{aligned} \text{Kekerapan/Frequency} &= \frac{2}{6} \\ &= \frac{1}{3} \end{aligned}$$

17 (a) (i)

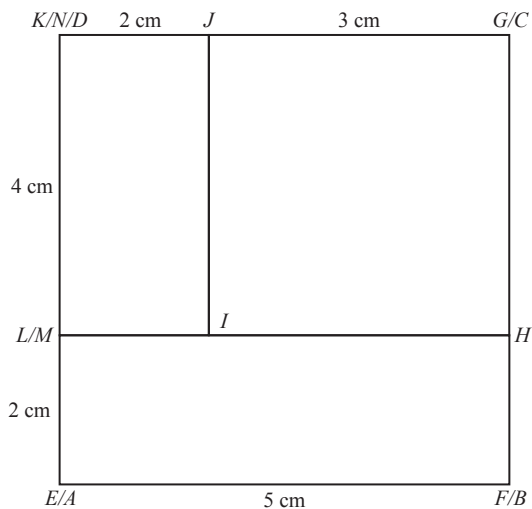

(ii)

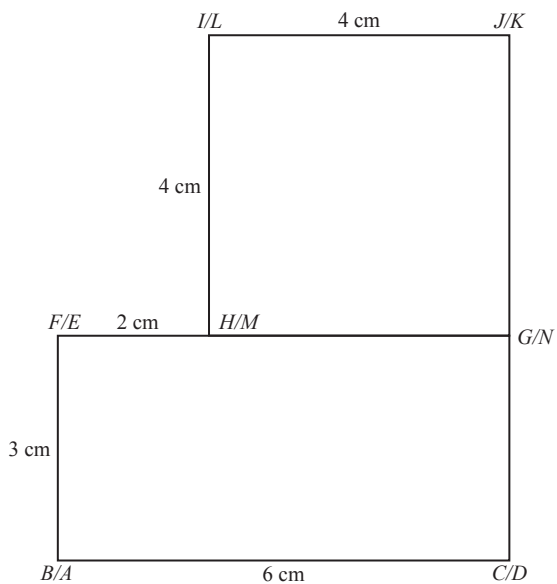

(iii)

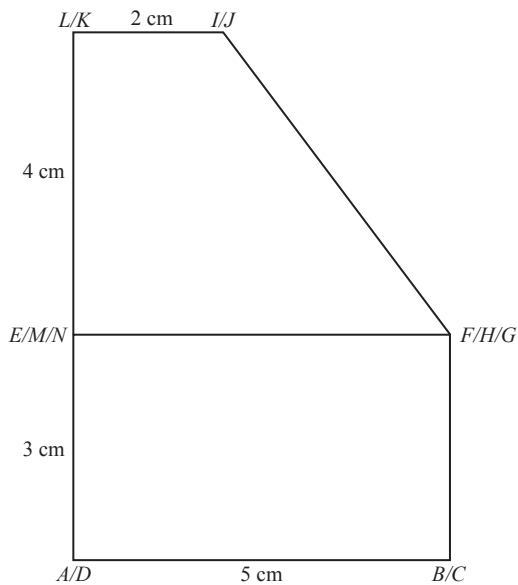

(b) Luas permukaan kadbod/*Surface area of the cardboard*  
 $= 21 \text{ cm} \times 29.7 \text{ cm}$   
 $= 623.7 \text{ cm}^2$

Luas permukaan kuboid/*Surface area of the cuboid*  
 $= 2(3 \times 5) + 2(5 \times 6) + 2(3 \times 6)$   
 $= 30 + 60 + 36$   
 $= 126 \text{ cm}^2$

Luas permukaan prisma/*Surface area of the prism*  
 $= (4 \times 2) + (4 \times 4) + 2 \left[ \frac{1}{2} \times (2 + 5) \times 4 \right] + 2(5 \times 4)$   
 $= 8 + 16 + 28 + 40$   
 $= 92 \text{ cm}^2$

Luas permukaan/*Surface area*  
 $= 126 + 92$   
 $= 218 \text{ cm}^2$

Ya, kerana luas permukaan model tersebut ialah  $218 \text{ cm}^2$  manakala luas permukaan kadbod ialah  $623.7 \text{ cm}^2$ .

Yes, because the surface area of the model is  $218 \text{ cm}^2$  while the surface area of the cardboard is  $623.7 \text{ cm}^2$ .

**KERTAS 1**

1 C

$$\begin{array}{r} \uparrow +1 \\ 0.04\overline{3}7 \\ = 0.044 \end{array}$$

Nilai 7 lebih besar daripada 5. Maka, +1 pada 3.  
The value of 7 is larger than 5. Hence, +1 on 3.

2 A

$$\begin{array}{r} \leftarrow \\ 5.\overline{4}35 \\ = 5.4 \end{array}$$

Nilai 3 lebih kecil daripada 5. Maka, tiada perubahan pada nilai 4.  
The value of 3 is smaller than 5. Hence, there is no change on the value of 4.

$$\begin{aligned} 5.4 \times 4 &= 21.6 \\ 21.6 &= 2.16 \times 10 \end{aligned}$$

3 A

Batu/Stones – 210 kg  
Meja/Table – 70% batu/stones  
Kerusi/Bench – 30% batu/stones

$$\frac{30}{100} \times 210 \text{ kg} = 63 \text{ kg}$$

$$\frac{63 \text{ kg}}{100} = 21 \text{ kg untuk sebiji kerusi/} \textit{of a bench}$$

4 C

$$\begin{array}{r} 1\ 0\ 2\ 1\ 1\ 2\ 0_3 \\ +\ 2\ 0\ 1\ 1\ 1\ 0\ 0_3 \\ \hline 1\ 0\ 1\ 0\ 2\ 2\ 2\ 0_3 \end{array}$$

5 B

$$\begin{aligned} 360^\circ - 145^\circ &= 215^\circ \\ x &= 900^\circ - 100^\circ - 215^\circ - 90^\circ - 90^\circ - 175^\circ - 135^\circ \\ &= 95^\circ \end{aligned}$$

6 C

1	0	0	1	$0_2$
$2^1$	$2^0$	$2^2$	$2^1$	$2^0$
$(1 \times 2^1) + (0 \times 2^0) = 2$		$(0 \times 2^2) + (1 \times 2^1) + (0 \times 2^0) = 2$		

$$22_8 \neq 21_8$$

7 A

$$\begin{aligned} \text{Sudut pedalaman heksagon/Interior angle of hexagon} &= \frac{(6-2) \times 180^\circ}{6} \\ &= 120^\circ \end{aligned}$$

$$\begin{aligned} s &= 120^\circ \\ r &= 120^\circ - 90^\circ \\ &= 30^\circ \\ 2r + s &= 2(30^\circ) + 120^\circ \\ &= 180^\circ \end{aligned}$$

8 B

$$\angle BED = \angle BDE = 70^\circ$$

$$\angle DBE = 180^\circ - 70^\circ - 70^\circ$$
$$= 40^\circ$$

$$x = 2 \times 40^\circ$$
$$= 80^\circ$$

9 A

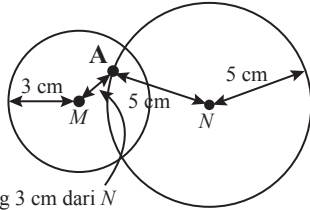

Kurang 3 cm dari  $N$   
Less than 3 cm from  $N$

10 B

Bergerak ke kiri sebanyak 3 unit. Kemudian, bergerak ke atas sebanyak 4 unit.  
Move left by 3 units. Then, move up by 4 units.

11 D

Perak = 21 helai/pieces

Selangor =  $x$

Kedah =  $y$

Jumlah bendera/Total of flags = 45 helai/pieces

Selangor:  $\frac{1}{3} = \frac{x}{45}$

$$x = \frac{1}{3} \times 45$$

$$x = 15$$

Kedah:  $\frac{1}{5} = \frac{y}{45}$

$$y = \frac{1}{5} \times 45$$

$$y = 9$$

12 C

Kuning/Yellow =  $x$

Hijau/Green = 25

$$\text{Hijau/Green: } \frac{1}{5} = \frac{25}{x}$$

$$(5 \times 25) - 25 = 100 \text{ biji bola/balls}$$

13 A

$$(2m - 1)^2 - (m - 2)(2m + 3)$$
$$= 4m^2 - 4m + 1 - (2m^2 + 3m - 4m - 6)$$
$$= 4m^2 - 4m + 1 - 2m^2 - 3m + 4m + 6$$
$$= 2m^2 - 3m + 7$$

14 B

$$\frac{3p-1}{\sqrt{q}} = \frac{2}{p}$$
$$\frac{(3p-1)p}{2} = \sqrt{q}$$
$$\sqrt{q} = \frac{3p^2-p}{2}$$
$$q = \left(\frac{3p^2-p}{2}\right)^2$$

15 A

$$y = x^3 + 3$$

Pintasan-y = 3  
y-intercept

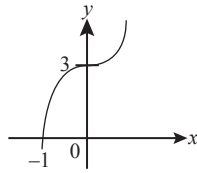

16 C

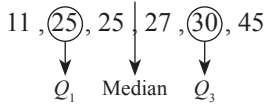

$$\text{Julat antara kuartil/Interquartile range} = Q_3 - Q_1$$
$$= 30 - 25$$
$$= 5$$

17 A

Mod/Mode = Bilangan murid paling ramai/The largest number of pupils  
Mod/Mode = 0 hari/day

18 C

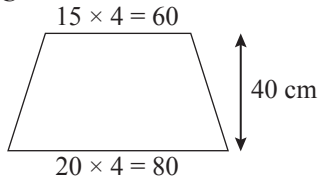

$$\text{Luas/Area} = \frac{1}{2} \times 40 \times (60 + 80) \text{ cm}^2$$
$$= 2800 \text{ cm}^2$$

19 B

$$\sqrt{13^2 - 5^2} = 12$$
$$\sqrt{12^2 + 35^2} = 37$$
$$\text{kos/cos } \theta = \frac{35}{37}$$

20 A

$$5 \times 3 = 15$$
$$3 \times 3 = 9$$
$$\sqrt{15^2 - 9^2} = 12$$
$$\tan y = \frac{12}{9}$$
$$= \frac{4}{3}$$

21 A

$$C \rightarrow D \rightarrow A$$

$$500 \text{ m} + 900 \text{ m} = 1\,400 \text{ m}$$

22 A

$$\text{Bucu/Vertex} = 5$$

$$\text{Tepi/Mode} = 7$$

$$\text{Darjah/Degree} = 2 \times 7 = 14$$

23 A

$$3x - 24 = 1 - 2x$$

$$3x + 2x = 1 + 24$$

$$5x = 25$$

$$x = \frac{25}{5}$$

$$= 5$$

24 A

Perjalanan dari Gurun ke Shah Alam = Luas bawah graf

*Journey from Gurun to Shah Alam = Area under a graph*

$$= \frac{1}{2} \times 110 \times (1.5 + 0.4)$$

$$= 104.5$$

Perjalanan dari Gurun ke Shah Alam = Luas bawah graf

*Journey from Shah Alam to Gurun = Area under a graph*

$$\frac{1}{2} \times 90 \times [2 + (2 - t)] = 104.5$$

$$2 + (2 - t) = 2.322$$

$$t = 1.68$$

25 D

$$2x + 5 > 11$$

$$2x > 11 - 5$$

$$x > \frac{6}{2}$$

$$x > 3$$

$$3x - 10 \leq 5$$

$$3x \leq 5 + 10$$

$$x \leq \frac{15}{3}$$

$$x \leq 5$$

$$x = 4, 5$$

26 B

$$8^{2x} = 4^{x-1}$$

$$(2^3)^{2x} = (2^2)^{x-1}$$

$$2^{6x} = 2^{2x-2}$$

$$6x = 2x - 2$$

$$4x = -2$$

$$x = -\frac{1}{2}$$

27 A

$$\frac{\cancel{(x-3)}(x+7)}{\cancel{x+5}} \times \frac{\cancel{x+5}}{(x+4)\cancel{(x-3)}} = \frac{x+7}{x+4}$$

28 D

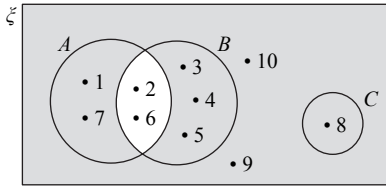

$$(A \cap B)^c = \{1, 3, 4, 5, 7, 8, 9, 10\}$$
$$n = 8$$

29 C

$$A \cup (B \cap C)$$

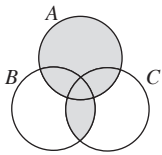

30 C

$$(8, 4), (0, 0)$$

$$m = \frac{4-0}{8-0}$$

$$= \frac{1}{2}$$

$$m_{AB} = m_{CD}$$

$$(4, -1), (0, y)$$

$$\frac{1}{2} = \frac{y - (-1)}{0 - 4}$$

$$\frac{1}{2} = \frac{y - (-1)}{0 - 4}$$

$$\frac{1}{2} = \frac{y + 1}{-4}$$

$$y = -3$$

$$\therefore C(0, -3)$$

31 D

$$3x + y = 7$$

$$y = -3x + 7$$

$$y = -3(0) + 7$$

$$y = 7$$

$$\text{Pintasan-}y/y\text{-intercept} = 7$$

32 B

$$P \propto \frac{Q}{\sqrt{M}}$$

$$P = \frac{kQ}{\sqrt{M}}$$

**33 D**

$$R(x, 0)$$

$$S(10, -5)$$

$$m = -5$$

$$-5 = \frac{0 - (-5)}{x - 10}$$

$$x - 10 = \frac{0 + 5}{-5}$$

$$x - 10 = \frac{5}{-5}$$

$$x = -1 + 10$$

$$x = 9$$

**34 C**

$$m \propto n^2$$

$$m = kn^2$$

$$1 = k(1)^2$$

$$k = 1$$

$$m = n^2$$

$$2 = j^2$$

$$j = \sqrt{2}$$

**35 B**

$$2 \begin{bmatrix} 2 & m \\ -1 & 9 \end{bmatrix} - \begin{bmatrix} 0 & -3 \\ 4 & 4 \end{bmatrix} = \begin{bmatrix} 4 & 11 \\ n & 4 \end{bmatrix}$$

$$\begin{bmatrix} 4 & 2m \\ -2 & 18 \end{bmatrix} - \begin{bmatrix} 0 & -3 \\ 4 & 4 \end{bmatrix} = \begin{bmatrix} 4 & 11 \\ n & 4 \end{bmatrix}$$

$$2m - (-3) = 11$$

$$2m = 11 - 3$$

$$m = \frac{8}{2}$$

$$= 4$$

$$-2 - 4 = n$$

$$n = -6$$

**36 A**

$$\begin{bmatrix} 2 & -3 \\ 4 & 1 \end{bmatrix} \begin{bmatrix} 1 & 0 \\ 0 & 1 \end{bmatrix} = \begin{bmatrix} 2(1) + -3(0) & 2(0) + -3(1) \\ 4(1) + 1(0) & 1(0) + 1(1) \end{bmatrix}$$
$$= \begin{bmatrix} 2 & -3 \\ 4 & 1 \end{bmatrix}$$

**37 D**

$$S \rightarrow R \rightarrow Q \rightarrow P \rightarrow T$$

**38 B**

$$\text{RM}200 \times \frac{6}{100} \div 12 \text{ bulan/months} \times 8 \text{ bulan/months} = \text{RM}8$$

$$\text{RM}200 + \text{RM}8 = \text{RM}208$$

**39 B**

$$(\text{RM}3\,800 \times 12) - \text{RM}5\,200 - \text{RM}2\,000 = \text{RM}38\,400$$

40 C

$$6.54 \times \frac{140\,000}{1\,000} = \text{RM}915.60$$

**KERTAS 2**

**Bahagian A**

**Section A**

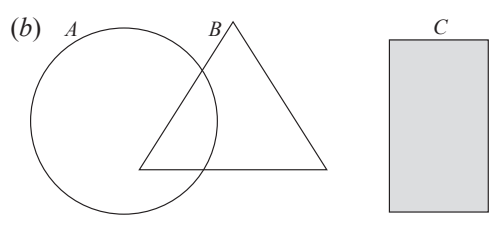
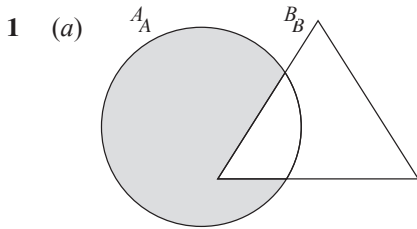

2 (a)  $\angle CHD$

$$(b) \tan \angle CHD = \frac{4}{9}$$

$$= 24^\circ$$

3  $2(3x + x - 1) = 22$

$$4x - 1 = 11$$

$$x = \frac{12}{4}$$

$$x = 3$$

$$\text{Luas/Area} = 3(3) \text{ cm} \times (3 - 1) \text{ cm}$$

$$= 9 \text{ cm} \times 2 \text{ cm}$$

$$= 18 \text{ cm}^2$$

4  $\frac{22}{7} \times 9^2 \times t - 3(16) = 3\,007$

$$254.57t = 3\,055$$

$$t = 12 \text{ cm}$$

5  $23x + 31y = 309$

$$66x - 23y = 103$$

$$23x + 31y = 309$$

$$x = \frac{309 - 31y}{23}$$

$$66\left(\frac{309 - 31y}{23}\right) - 23y = 103$$

$$20\,394 - 2\,046y - 529y = 2\,369$$

$$-2\,575y = -18\,025$$

$$y = 7$$

$$x = \frac{309 - 31(7)}{23}$$

$$x = 4$$

$$\therefore x = 4, y = 7$$

- 6 (a)  $x > y$  jika dan hanya jika  $y - x > 0$ .  
 $x > y$  if and only if  $y - x > 0$ .  
 (b) Benar/True  
 (c) Sebilangan/Some  
 (d) Antejadian/Antecedents:  $7x = 14$   
 Akibat/Consequences:  $x = 2$

7 (a)  $m_{OA} = \frac{-2 - 0}{3 - 0}$   
 $= \frac{-2}{3}$   
 $m_{OA} = m_{BC} = \frac{-2}{3}$   
 $y = mx + c$   
 $13 = \frac{-2}{3}(6) + c$   
 $c = 17$

$$\therefore y = \frac{-2}{3}x + 17$$

(b)  $y = \frac{-2}{3}x + 17$   
 Jika/If  $y = 0$   
 $0 = \frac{-2}{3}x + 17$   
 $x = \frac{51}{2}$   
 DE:  $y = \frac{51}{2}$

8  $x + y = 23$   
 $2x + 8y = 82$   
 $\begin{bmatrix} 1 & 1 \\ 2 & 8 \end{bmatrix} \begin{bmatrix} x \\ y \end{bmatrix} = \begin{bmatrix} 23 \\ 82 \end{bmatrix}$   
 $\begin{bmatrix} x \\ y \end{bmatrix} = \frac{1}{1(8) - 1(2)} \begin{bmatrix} 8 & -1 \\ -2 & 1 \end{bmatrix} \begin{bmatrix} 23 \\ 82 \end{bmatrix}$   
 $= \frac{1}{6} \begin{bmatrix} 8(23) + (-1)(82) \\ -2(23) + 1(82) \end{bmatrix}$   
 $= \frac{1}{6} \begin{bmatrix} 184 - 82 \\ -46 + 82 \end{bmatrix}$   
 $= \frac{1}{6} \begin{bmatrix} 102 \\ 36 \end{bmatrix}$   
 $= \begin{bmatrix} 17 \\ 6 \end{bmatrix}$

- 9 (a)  $\{(K, 2), (K, 0), (K, 0), (K, 5), (I, 2), (I, 0), (I, 0), (I, 5), (R, 2), (R, 0), (R, 0), (R, 5), (A, 2), (A, 0), (A, 0), (A, 5)\}$   
 (b) (i)  $\frac{4}{16} = \frac{1}{4}$   
 (ii)  $\frac{6}{16} = \frac{3}{8}$

10 (a) Persamaan/Equation 1:  
 $2x + 3y + x + 2y - 1 = 33$   
 $3x + 5y = 34$

Persamaan/Equation 2:  
 $x + 2y - 1 = 3(3x - y)$   
 $x + 2y - 1 = 9x - 3y$   
 $5y - 8x = 1$

(b) Persamaan/Equation 1 – Persamaan/Equation 2:

$$\begin{array}{r} 5y + 3x = 34 \\ - 5y - 8x = 1 \\ \hline 11x = 33 \\ x = 3 \end{array}$$

$$\begin{aligned} 3x + 5y &= 34 \\ y &= \frac{34 - 3x}{5} \\ &= \frac{34 - 3(3)}{5} \\ &= 5 \end{aligned}$$

**Bahagian B**  
**Section B**

11 (a)

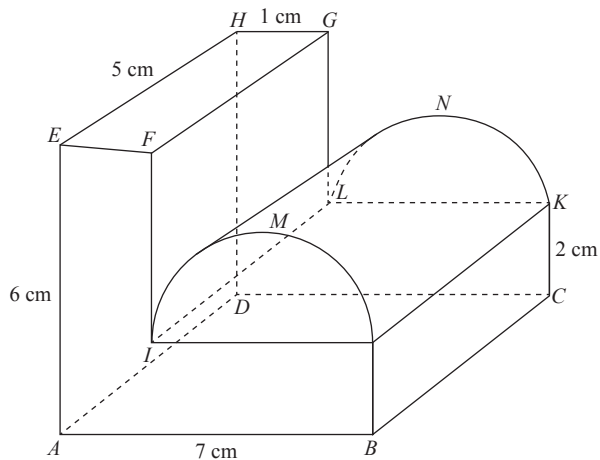

(b)  $(6 \times 5 \times 1) + (6 \times 5 \times 2) + \left(\frac{1}{2} \times \frac{22}{7} \times 3^2 \times 5\right)$   
 $= 30 \text{ cm}^3 + 60 \text{ cm}^3 + 70.71 \text{ cm}^3$   
 $= 160.71 \text{ cm}^3$

12 (a)

Batang Stem	Daun Leaf						
14	2	2	5	6			
15	3	5	6	6	7	7	
16	2	4	5	6	6	6	6
17	0	0					

Kekunci: 14|2 bermaksud 142 cm

Key: 14|2 means 142 cm

(b) (i)

$x$	$f$	$fx$	$x^2$	$fx^2$
1	2	2	1	2
2	5	10	4	20
3	4	12	9	36
4	6	24	16	96
5	5	25	25	125

$$\begin{aligned} \text{(ii) Min/Mean} = x &= \frac{\sum fx}{\sum f} \\ &= \frac{2 + 10 + 12 + 24 + 25}{2 + 5 + 4 + 6 + 5} \\ &= 3.318 \end{aligned}$$

$$\begin{aligned} \text{Varians/Variance} = \sigma^2 &= \frac{\sum fx^2}{\sum f} - (x)^2 \\ &= \frac{2 + 20 + 36 + 96 + 125}{2 + 5 + 4 + 6 + 5} - (3.318)^2 \\ &= 1.673 \end{aligned}$$

$$\begin{aligned} \text{Sisihan piawai/Standard deviation} = \sigma &= \sqrt{1.673} \\ &= 1.293 \end{aligned}$$

$$\begin{aligned} 13 \text{ (a) (i) } \tan \theta &= \frac{3}{4} = \frac{6}{JK} \\ JK &= \frac{6 \times 4}{3} \\ &= 8 \end{aligned}$$

$$\begin{aligned} MK &= \frac{8}{2} \\ &= 4 \text{ cm} \end{aligned}$$

$$\begin{aligned} \text{(ii) } \theta &= 180^\circ - 90^\circ - 30^\circ \\ &= 60^\circ \\ \text{kos/cos } LMK &= -\text{kos/cos } 60^\circ \\ &= -0.5 \end{aligned}$$

(b)  $R(22.5^\circ, 0.707)$   
 $S(112.5^\circ, -0.707)$

$$\begin{aligned} R: \tan 22.5^\circ &= \frac{\sin 22.5^\circ}{\text{kos/cos } 22.5^\circ} \\ &= \frac{0.383}{0.924} \\ &= 0.415 \end{aligned}$$

$$\begin{aligned} R: \tan 112.5^\circ &= \frac{\sin 112.5^\circ}{\text{kos/cos } 112.5^\circ} \\ &= \frac{0.924}{-0.383} \\ &= 0.242 \end{aligned}$$

- 14 (a) (i) Penjelmaan  $X$ : Pembesaran pada pusat  $(8, 2)$  dengan faktor skala  $\frac{1}{2}$ .

*Transformation X: Enlargement at centre  $(8, 2)$  with scale factor  $\frac{1}{2}$ .*

- (ii) Penjelmaan  $Y$ : Translasi  $\begin{pmatrix} 6 \\ 11 \end{pmatrix}$ .

*Transformation Y: Translation  $\begin{pmatrix} 6 \\ 11 \end{pmatrix}$ .*

$$(b) k = \frac{\text{Panjang imej/Length of image}}{\text{Panjang objek/Length of object}} = \frac{3}{6} = \frac{1}{2}$$

*Luas imej/Area of an image =  $k^2 \times$  Luas objek/Area of an object*

$$42 = \left(\frac{1}{2}\right)^2 \times \text{Luas objek/Area of an object}$$

*Luas objek/Area of an object =  $168 \text{ cm}^2$*

15 (a)  $P \propto \frac{Q^2}{\sqrt[3]{R}}$

$$P = \frac{KQ^2}{\sqrt[3]{R}}$$

(b)  $\frac{2}{9} = \frac{k(2)^2}{\sqrt[3]{216}}$

$$k = \frac{1}{3}$$

$$j = \frac{\frac{1}{3}(3)^2}{\sqrt[3]{8}}$$

$$j = \frac{3}{2}$$

(c)  $p = \frac{\frac{1}{3}(25)^2}{\sqrt[3]{27}}$

$$p = \frac{625}{9}$$

### Bahagian C

#### Section C

16 (a) (i)  $12 + 7 + 8 + x + 2x + 3 + 4x = 51$

$$7x + 30 = 51$$

$$x = 3$$

*Bilangan murid yang suka menonton dua jenis filem =  $7 + 3 + 2x$*

*Number of pupils who like to watch two types of movies*

$$= 7 + 3 + 2(3)$$

$$= 16 \text{ orang murid/pupils}$$

(ii)  $3 + x + 2x + 4x$

$$= 3 + 3 + 2(3) + 4(3)$$

$$= 24 \text{ orang murid/pupils}$$

(b) (i) Aliran tunai = Pendapatan – Perbelanjaan  
*Cash flow = Income – Expenses*  
 $= (2\,700 + 750) - (90 + 300 + 800 + 280 + 550)$   
 $= 3\,450 - 2\,020$   
 $= \text{RM}1\,430$   
 $\therefore$  Aliran tunai positif/*Positive cash flow*

(ii)  $\text{RM}13\,000 \div 4 = \text{RM}3\,250$   
 Lebihan/*Surplus*  $\text{RM}1\,430 + \text{RM}80 = \text{RM}1\,510$

Jumlah bulanan yang harus disimpan melebihi jumlah bulanan yang boleh disimpan mengikut corak perbelanjaan Linda.  
*The monthly amount to be saved exceeds the monthly amount that can be saved according to Linda's spending pattern.*

$\therefore$  Linda tidak boleh mencapai matlamat kewangannya./*Linda cannot achieve her financial goals.*

(c) Kos perubatan selepas deduktibel/*Medical costs after deductible*  
 $= \text{RM}30\,000 - \text{RM}550 = \text{RM}29\,450$

Kos yang ditanggung oleh syarikat insurans/*Costs incurred by the insurance company*  
 $= \frac{65}{100} \times \text{RM}29\,450 = \text{RM}19\,142.50$

Kos yang ditanggung oleh Cik Hannah/*Costs borne by Miss Hannah*  
 $= \left( \frac{35}{100} \times \text{RM}29\,450 \right) + \text{RM}550 = \text{RM}10\,857.50$

17 (a) (i) Julat/*Range*  $= \text{RM}18.90 - \text{RM}6.00 = \text{RM}12.90$   
 (ii) 9, 11, 12, 13, 18  
 Median = 12

(b)  $\frac{22}{7} \times 3.5^2 - \frac{22}{7} \times 2.7^2 = 15.59 \text{ cm}^2$

(c) Persamaan/*Equation* 1:  $30A + 25B = 1\,750$   
 Persamaan/*Equation* 2:  $60A + 10B = 1\,900$

(Persamaan/*Equation* 1)  $\times 2$ :  $60A + 50B = 3\,500$

$$\begin{array}{r} 60A + 50B = 3\,500 \\ - 60A + 10B = 1\,900 \\ \hline 40B = 1\,600 \\ B = \frac{1\,600}{40} \\ = 40 \end{array}$$

$30A + 25B = 1\,750$

$$\begin{aligned} A &= \frac{1\,750 - 25B}{30} \\ &= \frac{1\,750 - 25(40)}{30} \\ &= 25 \end{aligned}$$

$\therefore$  Pakej/*Package* A = RM25, Pakej/*Package* B = RM40

(d) Syarikat Insuran *A*/Insurance Company *A*:

Kos perubatan selepas deduktibel/*Medical costs after deductible*  
= RM20 000 – RM350 = RM19 650

Kos yang ditanggung oleh syarikat insurans/*Costs borne by the insurance company*  
=  $\frac{80}{100} \times \text{RM}19\,650 = \text{RM}15\,720$

Kos yang ditanggung oleh pembeli/*Costs borne by the buyer*  
=  $\left(\frac{20}{100} \times 19\,650\right) + \text{RM}350 = \text{RM}4\,280$

Syarikat Insuran *B*/Insurance Company *B*:

Kos perubatan selepas deduktibel/*Medical costs after deductible*  
= RM18 000 – RM1 000 = RM17 000

Kos yang ditanggung oleh syarikat insurans/*Costs borne by the insurance company*  
=  $\frac{75}{100} \times \text{RM}17\,000 = \text{RM}12\,750$

Kos yang ditanggung oleh pembeli/*Costs borne by the buyer*  
=  $\left(\frac{25}{100} \times 17\,000\right) + \text{RM}1\,000 = \text{RM}5\,250$

∴ Syarikat Insuran *A* menawarkan pakej yang lebih berbaloi.  
*Insurance Company A offers a more worthwhile package.*

**KERTAS 1**

1 **A**

$$\begin{array}{r} +1 \\ \uparrow \\ 8.03\overline{7}6 \\ = 8.04 \end{array}$$

← Nilai 7 lebih besar daripada 5. Maka, +1 pada 3.  
 ← The value of 7 is larger than 5. Hence, +1 on 3.

2 **C**

$$\begin{aligned} 6.102 \times 10^2 \times 10^{-2} \times 10^7 \\ = 6.102 \times 10^{2+(-2)+7} \\ = 6.102 \times 10^7 \end{aligned}$$

3 **B**

$$\begin{aligned} \frac{1}{2} \times (40 + 50) \times 30 \times 10 &= 13\,500 \\ \frac{13\,500}{3} &= 4\,500 \\ \frac{22}{7} \times 3.5^2 \times t &= 4\,500 \\ t &= 116.88 \text{ cm} \end{aligned}$$

4 **D**

$$(2 \times 6^3) + (3 \times 6^2) + (4 \times 6^1) + (5 \times 6^0) = 569$$

$$\begin{array}{r} 8 \overline{) 569} \\ 8 \overline{) 71} \rightarrow 1 \\ 8 \overline{) 8} \rightarrow 7 \\ 8 \overline{) 1} \rightarrow 0 \\ 0 \rightarrow 1 \end{array}$$

$$2345_6 \rightarrow 1071_8$$

5 **B**

$$\begin{array}{r} \phantom{+} \phantom{1} \phantom{2} \phantom{4} \phantom{2} \phantom{1} \phantom{4} \phantom{5} \\ \phantom{+} \phantom{1} \phantom{2} \phantom{4} \phantom{2} \phantom{1} \phantom{4} \phantom{5} \\ + \phantom{1} \phantom{2} \phantom{4} \phantom{2} \phantom{1} \phantom{4} \phantom{5} \\ \hline 1 \phantom{0} \phantom{4} \phantom{3} \phantom{0} \phantom{3} \phantom{2} \phantom{5} \end{array}$$

6 **D**

$$\begin{aligned} \frac{4^P \times 2^2}{8^P} &= 16 \\ \frac{2^{2P} \times 2^2}{2^{3P}} &= 2^4 \\ 2^{(2P+2-3P)} &= 2^4 \\ -P + 2 &= 4 \\ P &= -2 \end{aligned}$$

7 **B**

$$\frac{360^\circ}{60} = 6$$

Poligon 6 sisi = heksagon  
 Polygon of 6 sides = hexagon

8 A

$$\begin{aligned}\angle EBD &= \frac{(5-2) \times 180^\circ}{5} = 6 \\ &= 108^\circ\end{aligned}$$

$$x = \frac{180^\circ - 108^\circ}{2} = 36^\circ$$

$$y = 180^\circ - 2(62^\circ) = 56^\circ$$

$$x + y = 56^\circ + 36^\circ = 92^\circ$$

9 A

$$\begin{aligned}\angle ABC &= 180^\circ - 2(25^\circ) \\ &= 130^\circ\end{aligned}$$

$$\begin{aligned}\angle PRQ &= 130^\circ \div 2 \\ &= 65^\circ\end{aligned}$$

$$x = 360^\circ - 65^\circ - 40^\circ - 230^\circ = 25^\circ$$

10 C

$$\angle PSO = 90^\circ$$

$$\begin{aligned}\angle SOP &= 180^\circ - 90^\circ - 20^\circ \\ &= 70^\circ\end{aligned}$$

$$\begin{aligned}\angle QOT &= 180^\circ - 70^\circ \\ &= 110^\circ\end{aligned}$$

$$\begin{aligned}\angle QTO &= \frac{180^\circ - 110^\circ}{2} \\ &= 35^\circ\end{aligned}$$

$$x = 180^\circ - 35^\circ = 145^\circ$$

11 B

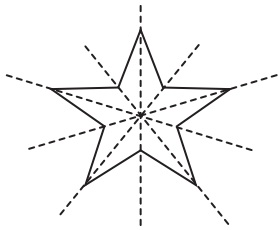

12 A

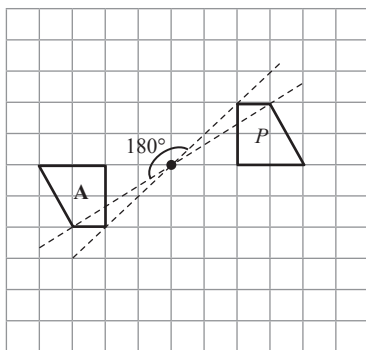

13 B

$$\begin{aligned}\sqrt{8^2 + 6^2} &= 10 \\ \cos \theta &= -\frac{6}{10} \\ &= -\frac{3}{5}\end{aligned}$$

14 A

Bentuk bagi graf/Shape of the graph,  $y = \cos \cos 2x$

15 A

$$\begin{aligned}6\,585 &= (5 \times 30 \times 35) + \left(\frac{22}{7} \times r^2 \times 90\right) \\ 6\,585 &= 5\,250 + 282.857r^2 \\ r^2 &= 4.72 \\ r &= 2.172\end{aligned}$$

16 B

Akaun pelaburan adalah bukan jenis akaun simpanan.  
*Investment account is not the type of savings account.*

17 A

$$\text{RM}78\,000 - \text{RM}5\,400 - \text{RM}1\,100 - \text{RM}3\,000 = \text{RM}68\,500$$

18 B

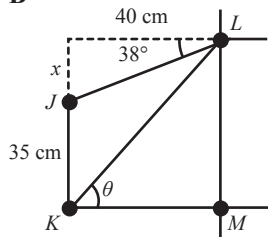

$$\tan 38^\circ = \frac{x}{40}$$

$$x = 31.25$$

$$\tan \theta = \frac{35 + 31.25}{40}$$

$$\theta = 59^\circ$$

19 C

$$\begin{aligned}\frac{3m}{2m} - \frac{(2-m) \times 2}{m \times 2} &= \frac{3m}{2m} - \frac{4-2m}{2m} \\ &= \frac{5m-4}{2m}\end{aligned}$$

20 D

$$\begin{aligned}5p^2 - 10pq - (9p^2 - 12pq + 4q^2) \\ = 5p^2 - 10pq - 9p^2 + 12pq - 4q^2 \\ = -4q^2 - 4p^2 + 2pq\end{aligned}$$

21 A

Untuk mencari pekali bagi  $xy$ , buang  $xy$ .  
*To find the coefficient of  $xy$ , remove the  $xy$ .*

$$2 \times \cancel{x} \times x \times \cancel{y} \times y \times y \times z$$

$$2x^2y^3z \rightarrow 2xy^2z$$

22 B

$$\frac{4.1}{100} \times 125\,000 \times 6 = \text{RM}30\,750$$

23 B

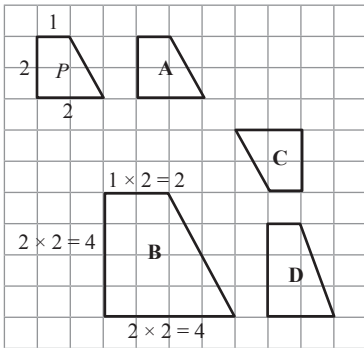

24 A

$$9m^2 \times m^3 \times 4m^2 = 36m^7$$

25 B

$$\begin{aligned} 4^{3n} \times 4^{-2} &= 4^{4n} \\ 3n - 2 &= 4n \\ -2 &= n \end{aligned}$$

26 A

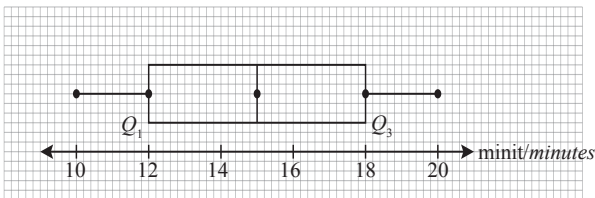

$$\begin{aligned} \text{Julat antara kuartil/Interquartile range} &= Q_3 - Q_1 \\ &= 18 - 12 \\ &= 6 \end{aligned}$$

27 A

$$\begin{aligned} 2x + 3 < 7 & \quad , \quad 3 - 3x \leq 15 \\ x < \frac{7-3}{2} & \quad x \geq \frac{15-3}{-3} \\ x < 2 & \quad x \geq -4 \end{aligned}$$

28 A

$$\begin{aligned} \text{Pecutan/Acceleration} &= \frac{110 - 70}{2} \\ &= 20 \text{ km j}^{-2}/\text{km h}^{-2} \end{aligned}$$

29 C

$$\begin{aligned} \frac{252 + x}{6} &= 50.4 + 2.6 \\ x &= 66 \end{aligned}$$

30 A

$$\frac{6 + 3 + 4 + 2 + 1}{2} = 9$$

2 biji buku mempunyai kekerapan longgokan sebanyak 9.  
2 books have a cumulative frequency of 9.

31 C

$$y = -3x^2 + 6x$$

Gantikan salah satu nilai  $x$  atau  $y$  daripada titik pada graf iaitu  $(0, 0)$  dan  $(2, 0)$  ke dalam setiap persamaan pada pilihan jawapan.

*Substitute one of the values of  $x$  or  $y$  from points at the graph which are  $(0, 0)$  and  $(2, 0)$  into each equation on the answer choices.*

Jika/If  $x = 0$ ,

$$y = -3(0)^2 + 6(0)$$

$$y = 0$$

$$\therefore (0, 0)$$

Jika/If  $x = 2$ ,

$$y = -3(2)^2 + 6(2)$$

$$y = 0$$

$$\therefore (2, 0)$$

32 D

$$\xi = \{f, g, h, i, j, k, l, m, n\}$$

$$(A \cup B) = \{h, k, l, m\}$$

$$(A \cup B)' = \text{selain/except } \{h, k, l, m\} \\ = \{f, g, i, j, n\}$$

33 A

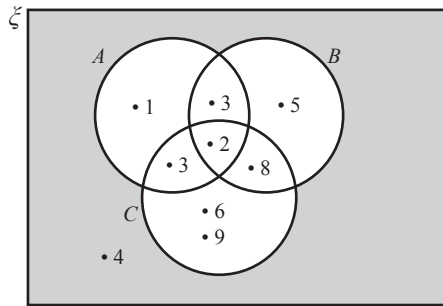

$$(A \cup B \cup C)' = \text{kawasan berlorek/shaded region} = \{4\}$$

$n$  mewakili bilangan unsur

$n$  represents the number of elements

$$\therefore n(A \cup B \cup C)' = 1$$

34 B

$$\frac{y}{5} = \frac{x}{2} + 1$$

$$\frac{y}{5} \times (5) = \frac{x}{2} \times (5) + 1 \times (5)$$

$$y = \frac{5}{2}x + 5$$

$$y = \frac{5}{2}(0) + 5$$

$$y = 5$$

35 B

$$\frac{7}{13} + \frac{2}{13} = \frac{9}{13}$$

36 A

$$\begin{aligned}p(3) &= 8 - p \\3p &= 8 - p \\4p &= 8 \\p &= 2\end{aligned}$$

37 A

$$P(A) = \frac{n(A)}{n(S)}$$

$$\begin{aligned}P(M \cap B) + P(B \cap M) &= \left(\frac{3}{11} \times \frac{8}{10}\right) + \left(\frac{8}{11} \times \frac{3}{10}\right) \\&= \frac{24}{55}\end{aligned}$$

38 C

$$\begin{pmatrix} 3 & 15 \\ 12 & -18 \end{pmatrix} - \begin{pmatrix} 7 & 14 \\ -21 & 0 \end{pmatrix} = \begin{pmatrix} -4 & 1 \\ 33 & -18 \end{pmatrix}$$

39 B

$$\begin{aligned}P(HB' + BH') &= \frac{2}{3} \times \frac{1}{5} + \frac{4}{5} \times \frac{1}{3} \\&= \frac{2}{15} + \frac{4}{15} \\&= \frac{2}{5}\end{aligned}$$

40 A

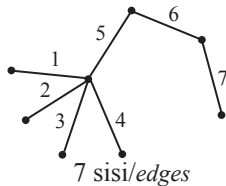
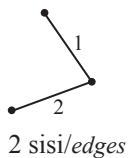
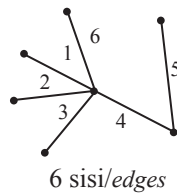
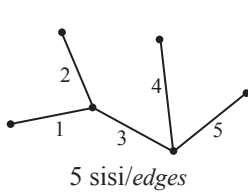

## KERTAS 2

### Bahagian A Section A

1 
$$\frac{2}{x+1} + \frac{1}{6} = \frac{15}{5x+1}$$

$$\frac{2(6)}{(x+1)(6)} + \frac{1(x+1)}{6(x+1)} = \frac{15}{5x+1}$$

$$\frac{12+x+1}{6x+6} = \frac{15}{5x+1}$$

$$\frac{13+x}{6x+6} = \frac{15}{5x+1}$$

$$(13+x)(5x+1) = 15(6x+6)$$

$$65x + 13 + 5x^2 + x = 90x + 90$$

$$5x^2 - 24x - 77 = 0$$

$$(5x+11)(x-7) = 0$$

$$5x + 11 = 0 \quad , \quad x - 7 = 0$$

$$x = -\frac{11}{5} \quad \quad \quad x = 7$$

$x$  ialah nombor positif/*is a positive number*,  $\therefore x = 7$

2

$$(x + 10)(x + 3) = 78$$

$$x^2 + 3x + 10x + 30 - 78 = 0$$

$$x^2 + 13x - 48 = 0$$

$$(x - 3)(x + 16) = 0$$

$$x - 3 = 0 \quad , \quad x + 16 = 0$$

$$x = 3 \quad \quad \quad x = -16$$

Jika/*If*  $x = 3$ ,

$$\text{Panjang/Length} = x + 3$$

$$= 3 + 3$$

$$= 6$$

$$\text{Lebar/Width} = x + 10$$

$$= 3 + 10$$

$$= 13$$

Jika/*If*  $x = -16$ ,

$$\text{Panjang/Length} = x + 3$$

$$= -16 + 3$$

$$= -13$$

$$\text{Lebar/Width} = x + 10$$

$$= -16 + 10$$

$$= -6$$

$\therefore x = 3$  kerana menghasilkan nilai panjang dan lebar yang positif.  
 $x = 3$  because it produces positive length and width values.

$$\text{Perimeter} = 2(6) + 2(13)$$

$$= 12 + 26$$

$$= 38 \text{ cm}$$

- 3 (a) Benar/*True*  
 (b) Semua/*All*  
 (c) Jika  $x$  ialah faktor bagi 8, maka  $x$  ialah faktor bagi 2.  
*If  $x$  is a factor of 8, then  $x$  is a factor of 2.*  
 (d) Bilangan angka bererti bagi 0.0843 bukan tiga.  
*The number of significant figures for 0.0843 is not three.*

4 (a)  $10P0111_2 = 127_8$

1		2		$7_8$				
↓		↓		↓				
0	0	1	0	1	0	1	1	$1_2$

$$10P0111_2 = 1010111_2$$

$$\therefore P = 1$$

$$(b) 102010_3 = \underline{300}_{-10}$$

$$\begin{aligned} & (1 \times 3^5) + (2 \times 3^3) + (1 \times 3^1) \\ & = 243 + 54 + 3 \\ & = 300 \end{aligned}$$

300 biji manga/mangoes  $\rightarrow$   $A \ B \ C$   $3 : 1 : 2$

$$A = \frac{3}{6} \times 300 = 150$$

$$B = \frac{1}{6} \times 300 = 50$$

$$C = \frac{2}{6} \times 300 = 100$$

$$\begin{aligned} 101_2 &= (1 \times 2^2) + (1 \times 2^0) \\ &= 4 + 1 \\ &= 5 \end{aligned}$$

Kemudian/Next,

$$A: 150 - 5 = 145$$

$$B: 50 + 5 = 55$$

$$C: 100$$

$$\begin{aligned} A : B : C &= 145 : 55 : 100 (\div 5) \\ &= 29 : 11 : 20 \end{aligned}$$

$$5 \quad (a) \quad 18 - x + x + 1 + 20 + x + 2 = 45$$

$$x = 4$$

Murid yang menggemari kedua-dua jenis makanan:

*Pupils who love both types of food:*

$$x + 1 = 4 + 1$$

$$= 5 \text{ orang murid/pupils}$$

$$(b) \quad 18 - x + 1 = 18 - 4 + 1$$

$$= 15 \text{ orang murid/pupils}$$

$$6 \quad (a) \quad B = \frac{1}{2} \times 20 \times 110 = 1\ 100$$

$$C = \frac{1}{2} \times 10 \times (80 + 110) = 950$$

$$D = (55 - 30)(80) = 2\ 000$$

$$E = \frac{1}{2} \times 80 \times 41 = 1\ 640$$

Masa Time	Lokasi Location	Jarak dari A Distance from A
9:00 pagi/a.m.	A	0 km
9:20 pagi/a.m.	B	1 100 km
9:30 pagi/a.m.	C	1 100 + 950 = 2 050 km
9:55 pagi/a.m.	D	1 100 + 950 + 2 000 = 4 050 km
10:36 pagi/a.m.	E	1 100 + 950 + 2 000 + 1 640 = 5 690 km

(b) Laju seragam adalah  $80 \text{ km min}^{-1}$  antara minit ke-30 dan 55.

*The uniform speed is  $80 \text{ km min}^{-1}$  between the minutes of 30 and 55.*



12 (a)

Masa (Minit) Time (Minutes)	Kekerapan Frequency	Titik tengah Midpoint
11 – 20	4	15.5
21 – 30	8	25.5
31 – 40	26	35.5
41 – 50	25	45.5
51 – 60	10	55.5

(b)

Bilangan murid  
Number of pupils

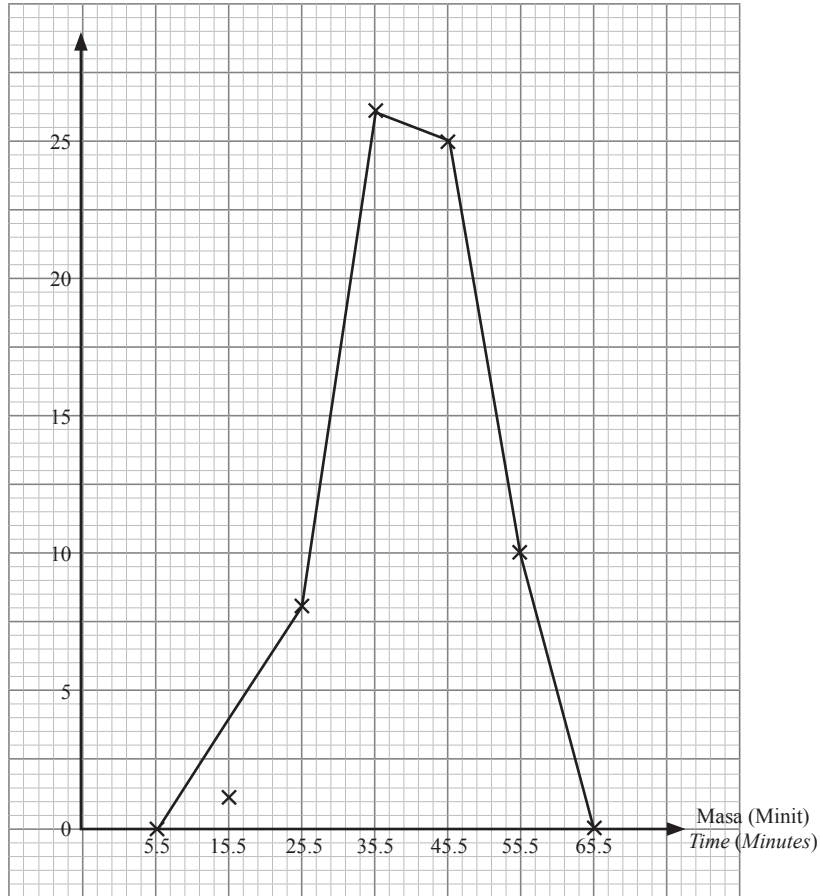

13 (a) (i)  $\sin 35^\circ = \frac{RS}{29}$

$$RS = \sin 35^\circ \times 29$$

$$= 16.634 \text{ cm}$$

(ii)  $\theta = 180^\circ - 90^\circ - 35^\circ$   
 $= 55^\circ$

$$\sin \angle TSU = \sin 55^\circ$$

$$= 0.819$$

(b)  $R(135^\circ, -1.414)$

(i)  $\text{kos}/\text{cos } R = \text{kos}/\text{cos } 135^\circ$   
 $= -0.707$

(ii)  $\tan R = \frac{\sin 135^\circ}{\text{kos}/\text{cos } 135^\circ}$   
 $= -1$

14 (a)  $x = \text{komputer riba/laptop}$

$y = \text{tablet}$

$x + y = 15$

$2\,500x + 1\,850y = 32\,300$

$$\begin{bmatrix} 1 & 1 \\ 2\,500 & 1\,850 \end{bmatrix} \begin{bmatrix} x \\ y \end{bmatrix} = \begin{bmatrix} 15 \\ 32\,300 \end{bmatrix}$$

(b)  $\begin{bmatrix} x \\ y \end{bmatrix} = \frac{1}{1(1\,850) - 1(2\,500)} \begin{bmatrix} 1\,850 & -1 \\ -2\,500 & 1 \end{bmatrix} \begin{bmatrix} 15 \\ 32\,300 \end{bmatrix}$   
 $= \frac{1}{-650} \begin{bmatrix} 1\,850(15) + (-1)(32\,300) \\ -2\,500(15) + (1)(32\,300) \end{bmatrix}$   
 $= \frac{1}{-650} \begin{bmatrix} -4\,550 \\ -5\,200 \end{bmatrix}$   
 $= \left( \frac{7}{8} \right)$

$\therefore \text{Komputer riba/Laptops} = 7$

$\text{Tablet/Tablets} = 8$

15 (a) Kos perubatan selepas deduktibel/*Medical costs after deductible*  
 $= \text{RM}19\,000 - \text{RM}1\,120 = \text{RM}17\,880$

Kos yang ditanggung oleh syarikat insurans/*Costs borne by the insurance company*

$$= \frac{80}{100} \times \text{RM}17\,880 = \text{RM}14\,304$$

Kos yang ditanggung oleh Zainab/*Costs borne by Zainab*

$$= \left( \frac{20}{100} \times \text{RM}17\,880 \right) + \text{RM}1\,120 = \text{RM}4\,696$$

(b) (i) Jumlah insurans yang harus dibeli/*The amount of insurance that must be purchased*

$$= \frac{80}{100} \times \text{RM}570\,000 = \text{RM}456\,000$$

(ii) Bayaran pampasan/*Compensation payment*

$$= \text{RM}120\,000 - \text{RM}3\,000 = \text{RM}117\,000$$

16 (a) Isi padu kon + isi padu hemisfera + isi padu silinder

*Volume of cone + volume of hemisphere + volume of cylinder*

$$= \left( \frac{1}{3} \times \frac{22}{7} \times 3^2 \times 5 \right) + \left( \frac{2}{3} \times \frac{22}{7} \times 3^2 \right) + \left( \frac{22}{7} \times 3^2 \times 8 \right) = 292.286 \text{ cm}^3$$

(b) Silinder + air =  $\frac{22}{7} \times 25^2 \times 32 = 62\,857.14$   
*Cylinder + water*

$$\text{Silinder + air + bola} = \frac{22}{7} \times 25^2 \times 37 = 72\,678.57$$

*Cylinder + water + ball*

$$\text{Isi padu bola} = 72\,678.57 - 62\,857.14 = 9\,821.43$$

*Volume of ball*

$$\frac{4}{3} \times \frac{22}{7} \times r^3 = 9\,821.43$$

$$r = 13.28 \text{ cm}$$

(c) (i) Cukai dasar/*Base tax* = RM150  
 Cukai atas baki/*Tax on the next balance* =  $(\text{RM}35\,000 - \text{RM}20\,000) \times 3\%$   
 = RM450

Cukai pendapatan/*Income tax*  
 = RM150 (cukai dasar/*base tax*) + RM450 (cukai atas baki/*tax on the next balance*) –  
 RM150 (zakat) – RM400 (rebat cukai/*tax rebate*)  
 = RM50

(ii) Pendapatan bercukai < RM35 000, Puan Rihai layak mendapat rebat cukai RM400.  
*Chargeable income < RM35 000, Mrs. Rihai eligibles to receive tax rebate RM400.*

RM400 (rebat/*rebate*) + RM150 (zakat) = RM550

Jumlah rebat yang layak ialah RM550.  
*Tax rebate obtained is RM550.*

(iii) Ya, lebihan cukai yang telah dibayar ialah  $(\text{RM}821 - \text{RM}50) = \text{RM}771$ .  
*Yes, an excess tax that has been paid is  $(\text{RM}821 - \text{RM}50) = \text{RM}771$ .*

17 (a) **Bank A**

$$MV = 7\,000 \left(1 + \frac{0.06}{2}\right)^{2(2)}$$

$$MV = 7\,878.56$$

**Bank B**

$$MV = 7\,000 \left(1 + \frac{0.03}{4}\right)^{4(2)}$$

$$MV = 7\,431.19$$

∴ Bank A adalah lebih berbaloi dipilih kerana pakej yang ditawarkan membolehkan Encik Hamka memperoleh faedah yang lebih tinggi.

*Bank A is more worth choosing because the package offered allows Mr. Hamka to earn higher interest.*

(b) (i)

Bulan <i>Months</i>	Jumlah pelaburan (RM) <i>Total of investment (RM)</i>	Harga seunit <i>Price per unit</i>	Bilangan unit <i>Number of unit</i>
Januari/ <i>January</i>	RM780	RM1.20	650
Februari/ <i>February</i>	RM780	RM0.90	867
Mac/ <i>March</i>	RM780	RM1.30	600
April	RM780	RM1.20	650
Mei/ <i>May</i>	RM780	RM1.20	650
Jun/ <i>June</i>	RM780	RM1.10	709
Julai/ <i>July</i>	RM780	RM1.15	678
Ogos/ <i>August</i>	RM780	RM0.95	821
September	RM780	RM1.30	600
Oktober/ <i>October</i>	RM780	RM1.00	780
November	RM780	RM1.00	780
Disember/ <i>December</i>	RM780	RM1.00	780

Jumlah unit/*Number of units*

$$= 650 + 867 + 600 + 650 + 650 + 709 + 678 + 821 + 600 + 780 + 780 + 780$$

$$= 8\,565 \text{ unit/units}$$

(ii) Pembelian sekali gus pada bulan Januari/*Lump sum purchased on January:*

$$\text{Modal/Capital} = \text{RM}780 \times 12 = \text{RM}9\,360$$

$$\text{RM}9\,360 \div \text{RM}1.20 \text{ seunit/per unit} = 7\,800 \text{ unit/units}$$

Strategi pemurataan yang dibuat oleh Encik Hamka adalah pilihan pelaburan yang bijak berbanding pembelian secara sekali gus pada bulan Januari kerana beliau akan memperoleh bilangan unit yang lebih banyak dengan modal yang sama.

*The averaging strategy made by Mr. Hamka is a wise investment choice as opposed to a lump sum purchase in January as he will acquire a larger number of units with the same capital.*

(c) (i)  $\text{Dividen/Dividend} = 6\,200 \times \text{RM}1.20 \times 0.075$   
 $= \text{RM}558$

(ii)  $\frac{6\,200}{8} = 775 \text{ unit/units}$

(iii)  $6\,200 + 775 = 6\,975 \text{ unit/units}$

**PEMBETULAN**  
**KERTAS MODEL SPM SET 3**  
**KERTAS 1 (SOALAN 38)**  
**KERTAS 2 (SOALAN 8, 11 & 12)**  
**HALAMAN 106, 113, 115 & 117**

38  $3\begin{pmatrix} 1 & 5 \\ 4 & -6 \end{pmatrix} - 7\begin{pmatrix} 1 & 2 \\ -3 & 0 \end{pmatrix} =$

A  $\begin{pmatrix} 10 & 29 \\ 33 & 18 \end{pmatrix}$

B  $\begin{pmatrix} -4 & 1 \\ 33 & 18 \end{pmatrix}$

C  $\begin{pmatrix} -4 & 1 \\ 33 & -18 \end{pmatrix}$

D  $\begin{pmatrix} -4 & 1 \\ 33 & 0 \end{pmatrix}$

- 8 Rajah 4 menunjukkan rantau berlorek yang memuaskan tiga ketaksamaan.  
 Diagram 4 shows the shaded region that satisfies three inequalities.

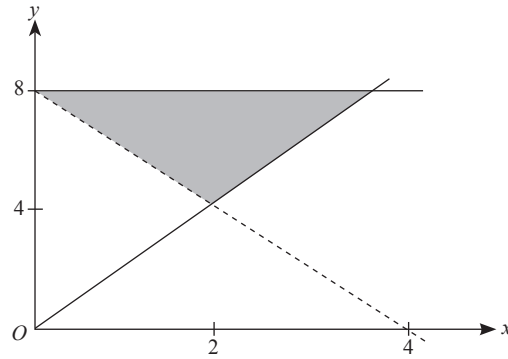

Rajah 4  
 Diagram 4

Nyatakan ketaksamaan-ketaksamaan itu.  
 State the inequalities.

[3 markah]  
 [3 marks]

Jawapan / Answer:

- 11 Rajah 5 menunjukkan sebuah gabungan pepejal dengan tapak  $ABCD$  terletak di atas satah mengufuk.  
 Diagram 5 shows a solid combination with base  $ABCD$  lies on the horizontal plane.

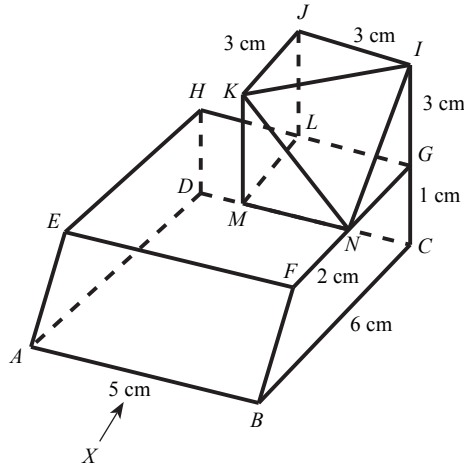

Rajah 5  
 Diagram 5

Lukis dengan skala penuh,  
 Draw to full scale,

- (a) pelan gabungan pepejal itu.  
 the plan of the composite solid.
- (b) dongakan pepejal itu pada satah mencancang yang selari dengan  $AB$  sebagaimana dilihat dari  $X$ .  
 the elevation of the solid on a vertical plane parallel to  $AB$  as viewed from  $X$ .

[9 markah]  
 [9 marks]

- 12 Jadual 3.1 adalah jadual kekerapan yang menunjukkan masa yang diambil oleh sekumpulan pekerja untuk menyiapkan tugas mereka.

*Table 3.1 is a frequency table that shows the time taken by a group of employees to complete their tasks.*

<b>Masa (Minit)</b> <i>Time (Minutes)</i>	11 – 20	21 – 30	31 – 40	41 – 50	51 – 60
<b>Kekerapan</b> <i>Frequency</i>	4	8	26	25	10

Jadual 3.1

Table 3.1

- (a) Lengkapkan Jadual 3.2 pada ruang jawapan berdasarkan data di atas.  
*Complete Table 3.2 in the answer space based on the data above.*
- (b) Untuk ceraian soalan ini, gunakan kertas graf yang disediakan pada halaman 118. Anda boleh menggunakan pembaris fleksible.

*For this part of the question, use the graph paper provided on page 118. You may use a flexible curve rule.*

Menggunakan skala 1 cm kepada 5 minit pada paksi mengufuk dan 2 cm kepada 5 orang pada paksi mencancang, lukis poligon kekerapan daripada data yang diberi.

*By using a scale of 1 cm to 5 minutes on the horizontal axis and 2 cm to 5 employees on the vertical axis, draw a frequency polygon from the given data.*

[9 markah]

[9 marks]

Jawapan / Answer:

(a)

<b>Masa (Minit)</b> <i>Time (Minutes)</i>	<b>Kekerapan</b> <i>Frequency</i>	<b>Titik tengah</b> <i>Midpoint</i>
11 – 20	4	
21 – 30	8	
31 – 40	26	
41 – 50	25	
51 – 60	10	

Jadual 3.2

Table 3.2

- (b) Rujuk graf pada halaman 118.  
*Refer to the graph on page 118.*

[Lihat halaman sebelah

SULIT